

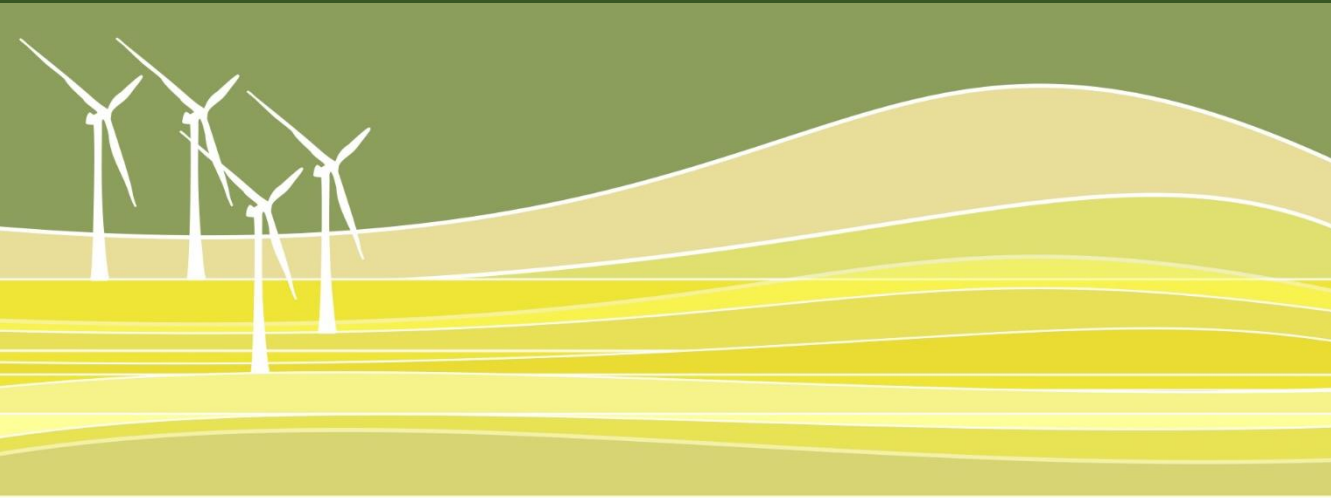

Empowered lives.  
Resilient nations.

Energy Conservation Building Code, 2017

# Design Guide



ENERGY EFFICIENCY IMPROVEMENTS  
IN COMMERCIAL BUILDING



© Bureau of Energy Efficiency, 2017

**Published by**

Bureau of Energy Efficiency

4th Floor, Sewa Bhawan, R. K.Puram, New Delhi - 110066

**Developed by**

Energy Efficiency Improvements in Commercial Buildings

United Nations Development Programme

55, Lodhi Estate, Lodhi Road, New Delhi – 110 003

*The contents of this publication may be freely reproduced for non-commercial purposes with attribution to the copyright holders.*

First published in December 2017

**Disclaimer**

*This document is produced as part of Component 2, Energy Efficiency improvements in Commercial Buildings (EECB). The views expressed in this publication, however, do not necessarily reflect those of the United Nations Development Programme and the Bureau of Energy Efficiency, Ministry of Power, Government of India.*



# Development Team

## **Bureau of Energy Efficiency**

Abhay Bakre, Director General

Saurabh Diddi, Director

Arijit Sengupta, Director

## **United Nations Development Programme**

S N Srinivas, Programme Analyst

Abdullah Nisar Siddiqui, Project Manger

Kanagaraj Ganesan, Consultant

## **Environmental Design Solutions**

Tanmay Tathagat

Anamika Prasad

Gurneet Singh

Mariyam Zakiah

Deepa Parekh

Ashutosh Gupta

Piyush Varma

Gopal Np

Lakshmi G Kamath

Megha Mittal

Abhishek Soni

Ajay Nahar

Arpit Chhapola

Manpreet Singh

Praveen Kumar

Shivam Gupta

Sourabh Das



*The goal of Energy Efficiency Improvements in Commercial Buildings (EECB) project is to reduce Green House Gas (GHG) emissions from the building sector in India through implementation of Energy Conservation Building Code (ECBC). EECB has 5 components, this document is one of the outputs under Component 2 which is on Technical Capacity Development.*





**Energy Conservation Building Code 2017**

# **DESIGN GUIDE**



# MESSAGE



**BUREAU OF ENERGY EFFICIENCY**  
*(Ministry of Power, Government of India)*



## **Abhay Bakre**

Director General, Bureau of Energy Efficiency

Energy efficiency is crucial for realizing our commitments to environmental sustainability and quality of life. Energy Conservation Building Code (ECBC 2017) is a progressive standard for guiding building construction and will drive the building sector in India towards very high benchmarks in building energy efficiency. Experience with building codes globally shows that building energy efficiency is driven by a combination of legislation and also with consumer demand for high performance buildings.

The Design Guide for Energy Efficient Commercial Buildings will help in understanding the process to integrate design requirements and specifications of the ECBC 2017 for the building design professionals. ECBC 2017 is the most important policy for integrating energy efficient technologies and concepts in buildings at the time of design and construction in order to ensure an efficient building stock for the future. The Design Guide will also provide guidance to architects and engineers through examples and calculations for meeting the requirements of the Code.

On behalf of BEE, I acknowledge the invaluable role of the UNDP GEF Program, which has been a close partner for ECBC implementation efforts of BEE over the last 5 years. The team led by Dr. S N Srinivas and supported by Mr. Abdullah Nisar Siddiqui have led the development of Design Guideline. The Design Guideline 2017 has been developed by Environmental Design Solutions [EDS] under contract with UNDP. I wish to acknowledge the effort of the EDS team in developing this comprehensive guideline. Their efforts will ensure that the requirements of ECBC 2017 are easier to comprehend and implement.

I am confident that the Design Guideline 2017 will be a useful document for the building industry to support effective implementation of ECBC 2017.

**Abhay Bakre**

Director General  
Bureau of Energy Efficiency



## **ABBREVIATIONS AND ACRONYMS**

AC	Alternating Current
AHU	Air Handling Unit
ASHRAE	The American Society of Heating, Refrigerating and Air-Conditioning Engineers
BEE	Bureau of Energy Efficiency
BUA	Built Up Area
CFC	Chloroflouro Carbon
DBT	Dry Bulb Temperature
DC	Direct Current
DEF	Daylight Extent Factor
DG	Diesel Generator
DOAS	Dedicated Outdoor Air System
DX	Direct Expansion
ECBC	Energy Conservation Building Code
ECM	Energy Conservation Measure
EEM	Energy Efficient Motors
EER	Energy Efficiency Ratio
EPI	Energy Performance Index
GSHP	Ground Source Heat Pump
HCFC	Hydrochlorofluorocarbons
HVAC	Heating, Ventilation and Air Conditioning
IPLV	Integrated Part Load Value
IRR	Internal Rate of Return
kVA	Kilo-Volt-Ampere
kWh	Kilo-Watt-Hour
LCC	Lifecycle Cost

LPD	Lighting Power Density
MRT	Mean Radiant Temperature
NBC	National Building Code
NPV	Net Present Value
PTAC	Packaged terminal air conditioners
PV	Photovoltaic
SFC	Specific Fuel Consumption
UDI	Useful Daylight Illuminance
UPS	Uninterrupted Power Supply
VAV	Variable Air Volume
VRF	Variable Refrigerant Flow

## TABLE OF CONTENTS

MEESAGE .....	xi
Chapter 1. INTRODUCTION .....	25
1.1 Objective .....	1
1.2 Energy Conservation Building Code .....	1
1.2.1 Scope .....	1
1.2.2 Approach .....	2
1.2.3 Climate Zones of India .....	4
1.3 How to use this Guideline .....	4
Chapter 2. FUNDAMENTALS .....	6
2.1 Building Physics .....	7
2.1.1 Heat transfer through buildings .....	7
2.1.2 External Thermal Loads .....	13
2.2 Thermal Comfort .....	16
2.2.1 Factors affecting Thermal Comfort .....	18
2.2.2 Comfort Temperature Range .....	21
2.3 Visual Comfort .....	24
Qualitative aspects of light .....	24
Quantitative aspects of light .....	24
Useful Daylight Index (UDI) .....	25
2.4 HVAC System .....	26
2.5 Energy Distribution in Commercial Buildings .....	29
Chapter 3. INTEGRATED DESIGN PROCESS .....	30
3.1 The Design Process .....	31
3.2 Climatic Analysis .....	33
3.2.1 Macro-Climatic Analysis .....	33
3.2.2 Micro-Climatic Analysis .....	36
3.2.3 Vegetation .....	36

3.2.4 Water Bodies .....	36
3.2.5 Terrain .....	37
3.3 Comfort Analysis.....	38
3.3.1 Thermal Comfort .....	38
3.4 Visual Comfort .....	39
3.5 Passive Design Strategies.....	41
3.6 Active Design Strategies .....	45
3.7 Cost Analysis .....	48
3.7.1 Formula:.....	48
3.7.2 Energy price calculation.....	48
Chapter 4. PASSIVE DESIGN STRATEGIES.....	51
4.1 General Design Strategies.....	52
4.1.1 Orientation .....	52
4.1.2 Building Form and Internal Layout .....	54
4.1.3 Shading and Daylighting .....	55
4.1.4 Natural Ventilation & Evaporative Cooling.....	56
4.2 Building Component Strategies .....	58
4.2.1 Roof.....	58
4.2.2 External Wall.....	61
4.2.3 Fenestration.....	61
Chapter 5. ACTIVE DESIGN STRATEGIES .....	63
5.1 Comfort Systems and Controls .....	64
5.1.1 HVAC System Types .....	64
5.1.2 HVAC Controls .....	75
5.1.3 Additional Controls For ECBC+ and SuperECBC Buildings.....	79
5.1.4 Additional Controls For SuperECBC Buildings.....	80
5.1.5 System Balancing .....	81
5.1.6 Condensers .....	81
5.1.7 Service Hot Water Heating .....	82



5.1.8 Economizers.....	83
5.1.9 Energy Recovery .....	84
5.2 Lighting and Controls .....	86
5.3 Electrical and Renewable Energy Systems.....	90
5.3.1 Transformer .....	90
5.3.2 Motors .....	95
5.3.3 Efficiency standards in motors- .....	98
5.3.4 Diesel generator .....	100
5.3.5 Uninterruptible Power Supply (UPS) .....	103
5.3.6 Renewable Energy Systems .....	106
5.3.7 Power Factor.....	110
Chapter 6. DESIGN GUIDELINES MATRIX .....	116
6.1 Climatic Zones of India.....	117
6.2 Hot and Dry Climate .....	121
6.3 Warm and Humid Climate .....	127
6.4 Temperate Climate .....	134
6.5 Composite Climate.....	140
6.6 Cold Climate.....	146
APPENDIX A .....	155
Appendix B.....	160
Appendix C.....	168
Appendix D .....	171
Appendix E.....	174
Appendix F.....	177

DRAFT

## LIST OF TABLES

Table 2-A Factors affecting comfort (Source: Szokolay, 2008) .....	18
Table 2-B Subjective reactions to air movement (Source : Szokolay, 2008).....	19
Table 3- A Recommended Values of Illuminance for some activities (National Building Code 2017, Part 8-Section 1) .....	40
Table 3- B Final Tariff rates (national average) – small office building.....	48
Table 5-A Minimum Requirements for Unitary, Split, Packaged Air Conditioners in ECBC Building .....	65
Table 5-B Minimum Requirements for Unitary, Split, Packaged Air Conditioners in ECBC+ Building.....	65
Table 5-C Minimum Requirements for Unitary, Split, Packaged Air Conditioners in SuperECBC Building .....	65
Table 5-D Minimum Energy Efficiency .....	67
Requirements for water cooled Chillers .....	67
Table 5-E Minimum Energy Efficiency Requirements for air cooled Chillers .....	68
Table 5-F Minimum Efficiency Requirements for VRF Air conditioners for ECBC Building* .....	69
Table 5-G BEE Star rating of DG sets.....	102
Table 6- A Climate Zone for Major Indian Cities .....	118
Table 6- B Design Guideline Matrix for Hot and Dry Climate Zone.....	122
Table 6- C Design Guideline Matrix for Warm and Humid Climate Zone .....	128
Table 6- D Design Guideline Matrix for Temperate Climate Zone .....	135
Table 6- E Design Guideline Matrix for Composite Climate Zone .....	141
Table 6- F Design Guideline Matrix for Cold Climate Zone .....	147
Table A- 1 Maximum Allowed EPI Ratios for Building in Composite Climate .....	155
Table A- 3 Maximum Allowed EPI Ratios for Building in Temperate Climate.....	156
Table A- 5 Maximum Allowed EPI Ratios for Building in Cold Climate .....	157
Table D- 1 Mechanical and Motor Efficiency Requirements for Fans in ECBC Buildings .....	171
Table D- 2 Mechanical and Motor Efficiency Requirements for Fans in ECBC+ Buildings .....	171

Table D- 3 Mechanical and Motor Efficiency Requirements for Fans in SuperECBC Buildings .....	171
Table D- 4 Pump Efficiency Requirements for ECBC Building .....	171
Table D- 5 Pump Efficiency Requirements for ECBC+ Building .....	172
Table D- 6 Pump Efficiency Requirements for SuperECBC Building .....	172
Table D- 7 Cooling Tower Efficiency Requirements for ECBC, ECBC+, and SuperECBC Buildings .....	172
Table D- 8 Minimum Efficiency Requirements for Oil and Gas Fired Boilers for ECBC building .....	172
Table D- 9 Minimum Efficiency Requirements for Oil and Gas Fired Boilers for ECBC+ and SuperECBC building .....	173
Table E- 1 Insulation Requirements for Pipes in ECBC Building .....	175
Table E- 2 Insulation Requirements for Pipes in ECBC+ Building .....	175
Table E- 3 Insulation Requirements for Pipes in SuperECBC Buildings .....	176
Table E- 4 Ductwork Insulation (R value in m2 . K/W) Requirements .....	176
Table F- 1 Interior Lighting Power for ECBC Buildings – Building Area Method .....	177
Table F- 2 Interior Lighting Power for ECBC+ Buildings – Building Area Method .....	178
Table F- 3 Interior Lighting Power for SuperECBC Buildings – Building Area Method ..	178
Table F- 4 Interior Lighting Power for ECBC Buildings – Space Function Method .....	180
Table F- 5 Interior Lighting Power for ECBC+ Buildings – Space Function Method .....	182
Table F- 6 Interior Lighting Power for SuperECBC Buildings – Space Function Method .....	183
Table F- 7 Exterior Building Lighting Power for ECBC Buildings .....	185
Table F- 8 Exterior Building Lighting Power for ECBC+ Buildings .....	185
Table F- 9 Exterior Building Lighting Power for SuperECBC Buildings .....	186

## LIST OF FIGURES

Figure 2-1 Fundamental of Heat Transfer .....	7
Figure 2-2 Heat transfer through conduction.....	8
Figure 2-3 Heat transfer through convection .....	9
Figure 2-4 Convection in horizontal spaces .....	9
Figure 2-5 Convection through ventilation.....	10
Figure 2-6 Stratification in atrium space .....	10
Figure 2-7 Forced convection .....	11
Figure 2-8 Solar radiation spectrum .....	12
Figure 2-9 Radiation heat transfer through roof .....	12
Figure 2-10 Glass and radiation .....	13
Figure 2-11 Thermal Loads in a building.....	14
Figure 2-12 Heat transfer in a Building system.....	15
Figure 2-13 Heat exchanges of the human body.....	17
Figure 2-14 Figure showing the Clo values for different levels of clothing .....	21
Figure 2-15 Example of a Psychrometric Chart (Source : Climate Consultant 6.0).....	22
Figure 2-16 Status Point plotted on Psychrometric Chart .....	23
Figure 2-17 Solar radiation spectrum .....	24
Figure 2-18 Figure explaining the difference between Luminance and Illuminance.....	25
Figure 2-19 HVAC System- Cooling Cycle.....	26
Figure 2-20 Energy Performance Index of Commercial Buildings in India in 2013 (Source : BEEP India).....	29
Figure 2-21 Energy Distribution in a typical office building (Source : EDS) .....	29
Figure 3- 1 Weather Data Summary for New Delhi, India (Source: Climate Consultant v6.0).....	35
Figure 3- 2 Monthly diurnal averages of Dry Bulb Temperatures and Solar Radiation for New Delhi, India (Source: Climate Consultant v6.0).....	35
Figure 3- 3 Typical Contour map (Source: ArcGIS).....	37
Figure 3- 4 Graph identifying periods of comfort and periods for which shading is required for New Delhi .....	41

Figure 3- 5 Passive Design Strategies to reduce thermal loads, analyzed from Psychrometric Chart for New Delhi (Source Climate Consultant 6.0) .....	43
Figure 3- 6 Graphs showing impact of variation in U-value and SHGC on the Total Energy Consumption per Unit Area for New Delhi .....	44
Figure 3- 7 Psychrometric Chart showing the percentage of time active cooling and heating is required after implementing the passive design measures (Source: Climate Consultant 6.0) .....	46
Figure 3- 8 Graph showing the impact of different active design measures on Annual Energy Use (kWh/m <sup>2</sup> /Yr).....	47
Figure 3- 9 Graph showing U-value correlation with LCC and Initial Cost .....	50
Figure 3- 10 Graph showing IRR and Payback Period .....	50
Figure 4- 1 Orientation of buildings in composite climates, to reduce summer solar gains and increase winter solar gains .....	52
Figure 4- 2 Different aspect ratios and impact of solar radiation.....	53
Figure 4- 3 Optimum S/V ratio to minimize heat gains .....	54
Figure 4- 4 Internal Layout of spaces to reduce solar gains .....	55
Figure 4- 5 Shading Design strategies.....	56
Figure 4- 6 Effective Strategies for cross-ventilation.....	57
Figure 4- 7 Building envelope strategies for areas with high diurnal variation .....	58
Figure 4- 8 Building envelope strategies for areas with low diurnal variation .....	59
Figure 4- 9 Working of a cool roof .....	60
Figure 4- 10 Working of a green roof .....	60
Figure 5- 1 Direct Evaporative Cooling System .....	70
Figure 5- 2 Indirect Evaporative Cooling.....	71
Figure 5- 3 Two-stage Evaporative Cooling .....	71
Figure 5- 4 Schematic Diagram of a Ground Source Heat Pump .....	74
Figure 5- 5 Schematic diagram of a transformer .....	90
Figure 5- 6 Types of Transformers .....	91
Figure 5- 7 Thermal insulation class (Source- NEMA service factor) .....	92
Figure 5- 8 Losses in Transformer (Source- BEE Book 3 Energy efficiency in electrical utilities).....	93
Figure 5- 9 Amorphous core transformer .....	94

Figure 5- 10 Conventional Transformer.....	94
Figure 5- 11 Standard Motor Components.....	95
Figure 5- 12 Types of Motors.....	96
Figure 5- 13 Induction motor.....	96
Figure 5- 14 Power loss in induction motor.....	97
Figure 5- 15 IE class (Source: Siemens).....	98
Figure 5- 16 Diesel Engine strokes.....	100
Figure 5- 17 Diesel Generator.....	101
Figure 5- 18 DG set panel.....	103
Figure 5- 19 UPS flow diagram.....	104
Figure 5- 20 Characteristics of a UPS.....	105
Figure 5- 21 UPS efficiency vs load (Source-Altruent Systems).....	106
Figure 5- 22 Solar PV system.....	107
Figure 5- 23 Roof top solar.....	108
Figure 5- 24 On-grid Solar.....	109
Figure 5- 25 Off-grid Solar.....	109
Figure 5- 26 Power components.....	110
Figure 5- 27 Power factor correction.....	112
Figure 5- 28 Capacitor bank.....	113
Figure 5- 29 Synchronous condenser.....	113
Figure 6- 1 Weather data for Jaipur (Hot and Dry Climate).....	121
Figure 6- 2 Weather data for Kolkata (Warm and Humid Climate).....	127
Figure 6- 3 Weather data for Bengaluru (Temperate Climate).....	134
Figure 6- 4 Weather data for New Delhi (Composite Climate).....	140
Figure 6- 5 Weather data for Srinagar (Cold Climate).....	146
Table A- 2 Maximum Allowed EPI Ratios for Building in Hot and Dry Climate.....	155
Table A- 4 Maximum Allowed EPI Ratios for Building in Warm and Humid Climate.....	157

DRAFT



# Chapter 1. INTRODUCTION

## **INTENT**

The chapter is an introduction to the Design Guideline for buildings compliant with ECBC 2017. It will define the Scope and Objectives of the book, as well as instruct the reader on how to use this guideline to extract the maximum out of it.



## 1.1 Objective

The intent of this guideline is to suggest passive and active design measures to the architects, designers, engineers and contractors on how to design buildings to meet Energy Conservation Building Code Compliant Building (ECBC) through the prescriptive compliance approach.

The guideline will also provide inputs for ECBC plus and Super-ECBC buildings, with an additional section on Integrated Design Process.

The guideline intends to provide passive and active design measures that are climate specific, and based on simulation outputs, which include process and plug loads.

Although there are many factors contributing to the energy performance of a building like the climate, site, building use and other factors, the design guideline matrix which forms the crux of this guideline, is carefully developed to provide ample options to the user of this guideline in selecting strategies that are more specific to the project.

## 1.2 Energy Conservation Building Code

### 1.2.1 Scope

The Energy Conservation Building Code (ECBC) applies to commercial buildings or building complexes that have a connected load of 100 kW or greater or a contract demand of 120 kVA.

The focus of this Guideline is new construction and, some of the recommendations may also be applied to existing buildings and retrofitting projects.

The guideline is specific to the scope of the ECBC 2017 covering the main building design components, i.e. Building Envelope, Comfort systems and Controls, Lighting and controls and Electrical and Renewable Energy systems.

#### 1.2.1.1 Building Systems

The building Systems under the scope of ECBC 2017 include:

- Building Envelope
- Comfort Systems and Controls

- Lighting and Controls
- Electrical and Renewable Energy Systems

#### 1.2.1.2 Building Categories

The design guideline can be applied to the following building categories:

- Hospitality
- Health Care
- Assembly
- Business
- Educational
- Shopping Complex
- Mixed-use Building

#### 1.2.2 Approach

##### 1.2.2.1 Energy Performance Index

The design guidelines will aid the user to achieve the Energy Performance Index (EPI) through the EPI Ratio specified for ECBC buildings, as per Appendix D § 14 of ECBC 2017

$$EPI\ Ratio = \frac{EPI\ of\ Proposed\ Building}{EPI\ of\ Baseline\ Building}$$

where,

*Proposed Building* is as per the actual design of the building, and complies with all the mandatory requirements of ECBC, and

*Baseline Building* is a standardized building that has the same building floor area, gross wall area and gross roof area as the Proposed Building, complies with the mandatory requirements, and minimally complies with prescriptive requirements of ECBC 2017

For the EPI's of buildings refer to Appendix A of this book.

##### 1.2.2.2 Compliance Options

There are two options through which the building can be complied with the Code:

- a. Prescriptive Method

A building complies with the code through the Prescriptive Method if the Building Envelope components, Comfort Systems and Controls, Lighting and Controls, and Electrical System and Renewable Energy Systems meet the minimum (or maximum) values as prescribed from §4.0 to §7.0 in ECBC 2017

In addition to this, the building should meet all mandatory requirements of §4.0 to §7.0 in ECBC 2017

#### *Building Trade-Off Method*

The Building Trade-off Method can be used as an alternative compliance approach for prescriptive criteria of §4.3.1 to §4.3.3.

The approach works on the basis of comparing Environmental Performance Factor (EPF) of Proposed Building and Standard building. The EPF of proposed building should be less than or equal to EPF of the Standard Building, calculated as per §4.3.5. The compliance to the other sections has to be as per the prescriptive method.

#### b. Whole Building Performance Method

An alternate compliance approach is through Whole Building Performance method, where the Annual energy use should be less than that of Standard Design, and may not comply with the prescriptive requirements of §4 to §7. The mandatory requirements of §4 to §7 have to be met during this approach.

### 1.2.3 Climate Zones of India

The Climate zones of India covered under this guideline include:

- Composite
- Hot and Dry
- Warm and Humid
- Temperate
- Cold

### 1.3 How to use this Guideline

Review **Chapter 2** to understand the Fundamentals of Building Sciences or factors that contribute to the Energy consumption of a building

Review **Chapter 3** to understand the Integrative Design Process, the overview of steps to achieve an energy efficient building, how they contribute to optimizing the building and the different tools available to perform analysis and simulations

Review **Chapter 4** to understand the general architectural design guidelines and climate specific passive strategies that can be applied to make the building energy efficient with respect to the building envelope

Review **Chapter 5** to understand the active mechanisms and controls which contribute to the energy efficiency of the building and strategies that can be employed to improve their efficiency

Use **Chapter 6** as a design tool with climate specific Design strategy matrix. The chapter contains prescriptive packages for energy savings that can be used to achieve the Super ECBC code compliance

Refer to the appendices for additional information on:

**Appendix A**

Recommended Maximum allowed EPI ratio for Buildings in all the five climatic zones of India as per ECBC 2017

**Appendix B**

Basics of U-value calculations for construction assemblies and references for Wall Assemblies

**Appendix C**

References for Roof Assemblies

**Appendix D**

Recommended values for Motor, Pump, Cooling Tower and Boiler efficiency

**Appendix E**

Recommended values for Piping and Ducting insulation as per ECBC 2017

**Appendix F**

Recommended Lighting Power Density for Building Area Method and Space Function Method as per ECBC 2017

# Chapter 2. FUNDAMENTALS

## INTENT

The first step in understanding how a building works and identifying the components impacting its energy use, is through having a thorough understanding of the building sciences. This chapter contains an elaborate description of the heat transfer in the building, thermal comfort and comfort systems and their energy use.

## SECTION ORGANIZATION

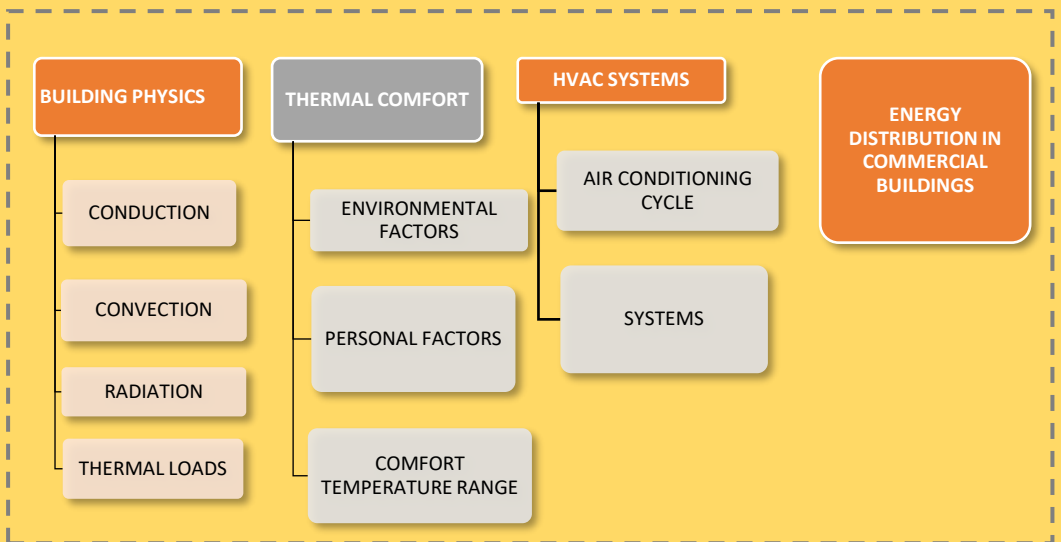



## 2.1 Building Physics

A typical Building is an open system; therefore, it exchanges heat as well as mass(air) with surroundings. Though the transfer processes are much more complex, building's design and operating parameters need to follow them. Fundamentally, heat and mass transfer decide the indoor air conditioning strategies for a building which could be either natural or mechanical.

### 2.1.1 Heat transfer through buildings

Just like the potential gradient between top most and lowest point of a waterfall causes water to fall, likewise the existence of temperature gradient would cause heat to transfer from one point to another point irrespective of the medium.

For a typical building heat transfer takes place across the surfaces (due to variation in surrounding temperature) as well as inside the building (due to various heat generating activity).

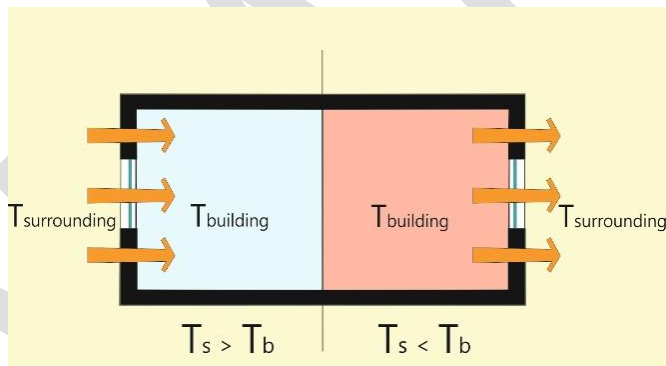
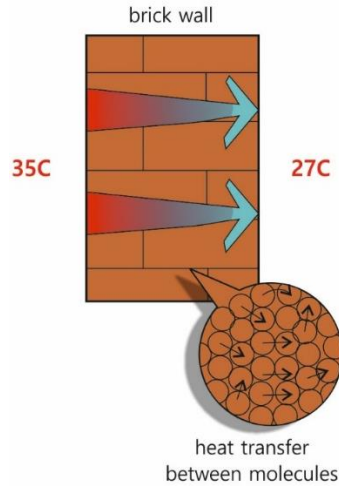

Figure 2-1 Fundamental of Heat Transfer

If the surrounding temperature is greater than inside temperature of the building then heat transfer takes place from surrounding to building and vice versa. Heat is transferred by three mechanisms- **Conduction, Convection and Radiation.**

**Conduction** is the heat transfer through a solid medium due to temperature difference. There are two things required for conduction to take place – surface contact and temperature difference. For example, heat transfer across a 230mm brick wall will take place due to temperature difference across the wall (Figure 2-2). Heat will be transferred from one brick molecule to the other that are in contact.



*Figure 2-2 Heat transfer through conduction*

The rate of heat transfer is determined by the material property. Ideally, we want the building envelope to be a bad conductor of heat so that heat gains or losses can be minimized. This will result in a largely stable temperature inside the building which is desired for occupant comfort.

**Convection** is the heat transfer through a fluid medium such as air or water. Convection within the envelope assembly will depend on the temperature difference across the surfaces and also the air speed.

For example, heat transfer across an air gap within a wall will take place through convection (Figure 2-3). The heated exterior wall surface transfers heat to the air film on surface 2. Warm air becomes buoyant and starts moving and transferring heat to the cooler air molecules. Thus, warm air moves upwards and the cool air falls downward resulting in a cyclical movement within the wall cavity. This air movement within the cavity transfers heat from surface 2 to 3 through convection. This movement will continue until there is no temperature difference.



the buildings through openable fenestrations and either warms up or cools the interiors through air movement (Figure 2-5).

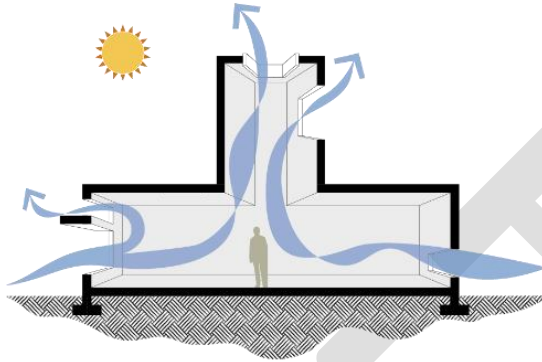

*Figure 2-5 Convection through ventilation*

In tall spaces, warm air tends to rise and accumulate near the ceiling due to the same principle of buoyancy (Figure 2-6). This is called stratification which is a result of convection.

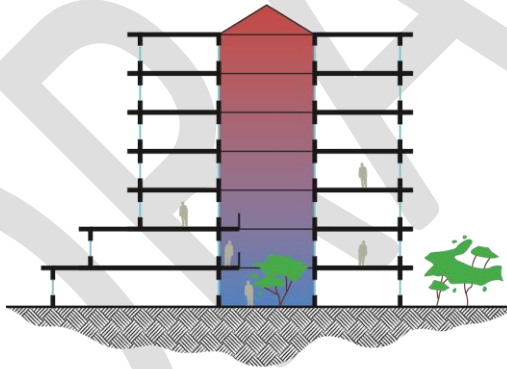

*Figure 2-6 Stratification in atrium space*

Exhausting the warm air will from higher outlet will create a pressure difference to pull in cool air from the lower inlet. This is a forced convection strategy in passive building design to assist air flow inside the building (Figure 2-7). In such cases, convection is desired to ensure air movement for comfort.

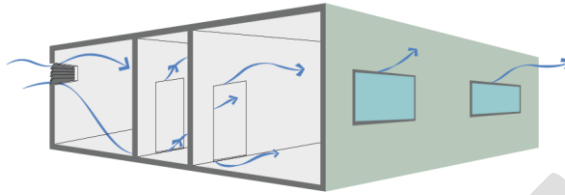

Figure 2-7 Forced convection

In a closed mechanically conditioned building, convection can take place by air entering or exiting through window cracks and other construction joints. When warm outside air enters the interiors, it adds heat to the space which eventually increases the cooling requirement. Similarly, when cold outside air enters the warm space in winters, it will increase the heating requirement. This is called infiltration which is desired to be minimized in energy efficient buildings.

**Radiation** is the heat transfer through electromagnetic radiation. All bodies facing an air space or a vacuum emit and absorb radiant energy continuously. Heat transfer by radiation will take place from a warmer surface to a cooler one. For example, if you are sitting close to a fire place, you feel warm because your body is gaining heat by radiation.

In the context of energy conservation, it is important to understand solar radiation and its impact on buildings. Solar radiation is an electromagnetic wave comprising of ultraviolet, visible and infrared radiation. The 'solar infrared' component has a short wavelength primarily due to its very high temperature.

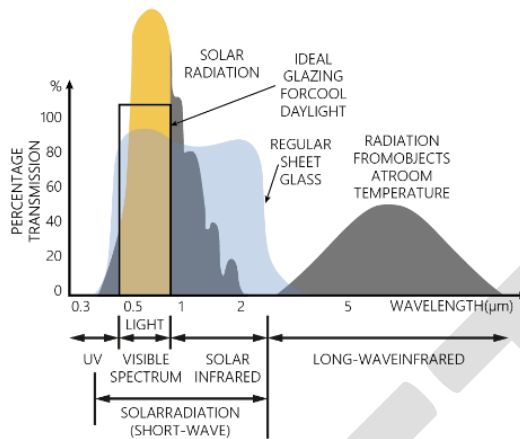

Figure 2-8 Solar radiation spectrum

When the ‘solar infrared’ component comes in contact with the earth or any object or a building, it transfers its energy to the object/building in the form of heat. This phenomenon is known as solar radiation on heat transfer. When the building or objects warm up, they radiate heat as long wave infrared radiation.

When solar radiation is incident on the roof, the outer surface becomes warm and starts conducting heat through the material. When the inner surface becomes warm, it starts radiating heat inside the room (Figure 2-9).

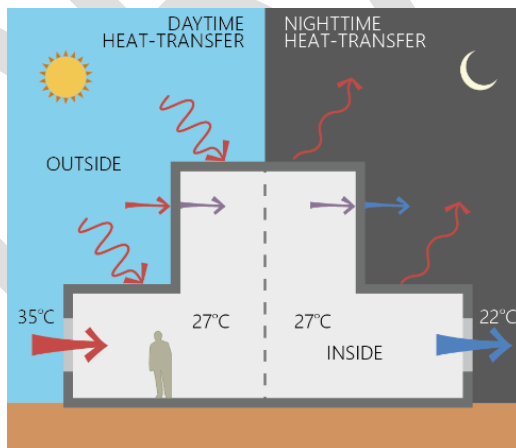

Figure 2-9 Radiation heat transfer through roof

During nighttime, the process is reversed. The outside surface of the roof start radiating heat towards the cool night sky.

Radiation is affected by the surface property of the material. For example, light colored surface will absorb less heat compared to a dark colored surface consequently impacting the overall heat content of the material.

Transparent materials such as glass interacts very differently with solar radiation (short wavelength) than with long wave infrared radiation.

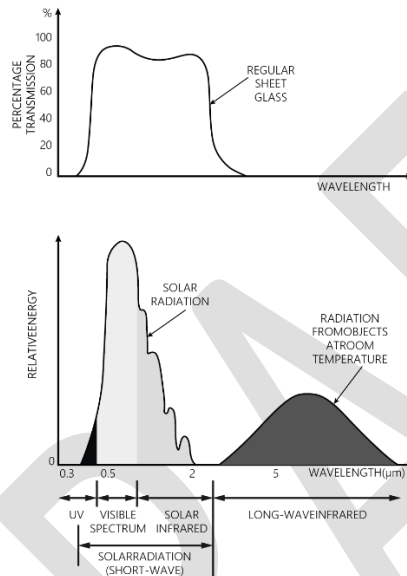

Figure 2-10 Glass and radiation

Glass is “selective” in what can pass through it. The high temperature short-wave solar radiation is able to pass right through a regular clear glass and ends inside the space as heat. As the objects inside the space get warmed, they start emitting radiation in the long-wave infrared spectrum. As shown in Figure 2-10, glass is opaque to the long-wave infrared radiation and hence it traps a part of this energy and the room slowly heats up. This is called the *greenhouse effect*. This is the reason spaces enclosed by glass in a hot climate need increased air conditioning.

### 2.1.2 External Thermal Loads

All buildings are subject to external thermal loads. Just like a building is designed to meet the structural loads, it should also be designed to meet the thermal loads. Thermal loads depend

on the climate, the building envelope and what is inside the building.

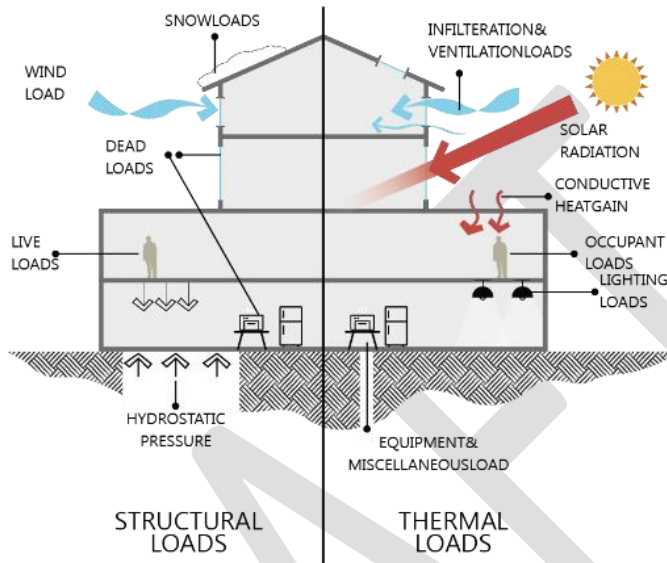

Figure 2-11 Thermal Loads in a building

Climate plays a very important role in determining thermal loads. A building located in a hot and dry climate will need more cooling compared to a moderate climate. This is called **external loads**.

The envelope design must try to counter the external loads by proper thermal design of the walls, roof and fenestrations. The property of these materials will determine the heat gain from outside to inside. This is called **envelope load**. For example, a glass curtain wall will result in more heat gain as compared to 230mm brick wall of the same area. Thus, the envelope load of a 80% glazed building is larger than a 30% glazed building with more opaque walls. If such a building was located in a hot-humid climate, then the cooling load for the 80% glazed building will be much larger than the 30% glazed building. Moreover, shading elements impact the heat gain as well.

The total air conditioning load on any building consists of both sensible as well as latent load components. The **sensible load**



affects dry bulb temperature, while the **latent load** affects the moisture content of the conditioned space.

e.g. In data center, to cool the machines or computer only sensible cooling is required whereas for occupied spaces both sensible as well as latent load requirement has to be met.

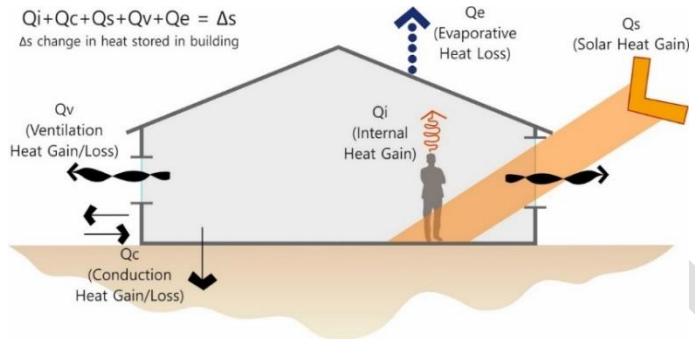

Figure 2-12 Heat transfer in a Building system

It takes energy to either add heat to remove heat. Hence larger thermal loads will mean more energy used by the building to provide thermal comfort.

People, lights and equipment inside a building add heat to the space. This is called **internal loads**. For example, the internal loads of an hotel will be larger than that of a school since there will be more lights, equipment and people on hotel. Except for the number of people using a building, all other aspects can be controlled by building design.

Thus, building design including the form, orientation, wall and roof construction, fenestration area, shading devices, surface finishes, lighting design, equipment efficiency, etc plays a significant role in determining the thermal loads. The design process for sustainable and energy efficient buildings requires that such design decisions are taken during early stage design process.

The ECBC gives minimum requirements for building envelope to meet the thermal loads as per different climate.

The Internal and external thermal loads translate to heating and cooling loads, that is the amount of heat energy required to heat and cool the building, and control humidity within the building.

Loads are calculated as the amount of energy that is required to be moved into or out of the building to keep the temperature at a specified point (setpoint). The principal of heating and cooling loads is that, if heat gains are greater than envelope and ventilation losses, the building has a net **cooling load**(the building is hot).

On the other hand, if heat losses are greater than the internal gains, the building or space has a net **heating load** (the building is cold).

The heating thermostat setpoint is different than the cooling thermostat setpoint, to save energy and human thermal comfort

## 2.2 Thermal Comfort

The metabolic processes inside the human body result in the emission of heat. Generally, the heat output is taken as 100 W, but it can range between 70 W (sleep) to 700 W (vigorous activity e.g. playing squash). In order to maintain the body 'core' temperature at 37°C, this heat must be dissipated to the surrounding environment.

The process of obtaining thermal stability is called 'thermoregulation', which is done through the three physical processes: convection, radiation and evaporation. This process can be expressed as (Szokolay, 2008)

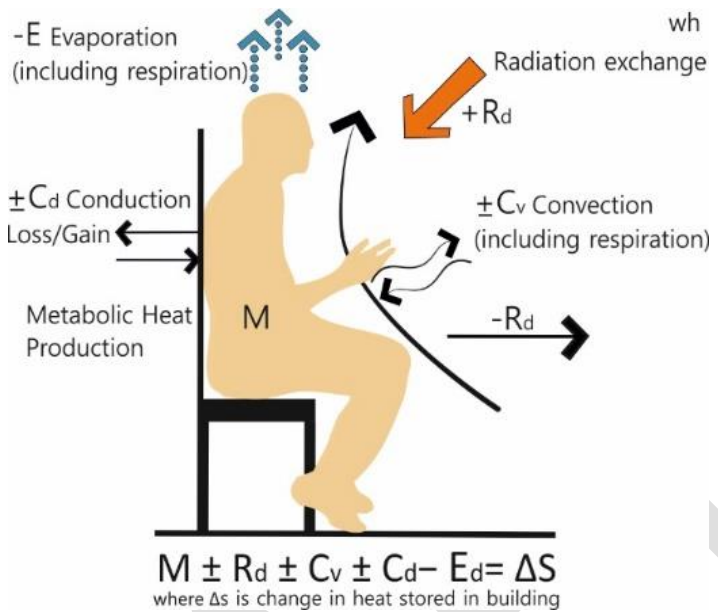

Figure 2-13 Heat exchanges of the human body

$$M \pm R_d \pm C_v \pm C_d - E = \Delta S \quad (1)$$

Where  $M$  = metabolic heat production

$R_d$  = net radiation exchange

$C_v$  = convection (including respiration)

$C_d$  = conduction

$E$  = evaporation (including respiration)

$\Delta S$  = change in stored heat

Thermal comfort for the human body is achieved when  $\Delta S$  is zero. However, comfort varies from person to person and requires a subjective evaluation (ASHRAE, 1997). Since it is not possible to satisfy every individual, several laboratory and field studies have been done to provide statistical data to define thermal comfort conditions for a specified percentage of occupants.

## 2.2.1 Factors affecting Thermal Comfort

The factors affecting thermal comfort can be categorized into three sets:

Table 2-A Factors affecting comfort (Source: Szokolay, 2008)

<i>Environmental</i>	<i>Personal</i>	<i>Contributing factors</i>
Air temperature	Metabolic rate (activity)	Food and drink
Air movement	Clothing	Body shape
Humidity	State of health	Subcutaneous fat
Radiation	Acclimatization	Age and gender

### 2.2.1.1 Environmental Factors

**Air Temperature:** Air temperature is the most important factor as it determines convective heat dissipation. Heat will be carried away by the air, if the temperature of the air is lower than that of the skin. Therefore, the cooling (or heating) effect of the air is directly dependent on the difference between air temperature and skin temperature (or clothing surface temperature).

**Air Movement:** Air movement contributes to the physiological cooling effect as it accelerates convection. The convective heat loss is relative to the body surface, it changes the skin and clothing surface heat transfer coefficient and increases evaporation from the skin.

The physiological cooling effect can be estimated by (Szokolay, 2008) :

$$dT = 6 \times v_e - 1.6 \times v_e^2 \quad (2)$$

Now,

$$v_e = v - 0.2 \quad (3)$$

Where,

$dT$  = apparent cooling effect of air movement

$v_e$  = effective air velocity

$V$  = air velocity (m/s) at the body surface (This expression is valid up to 2 m/s )

When the moving air in contact with the body at higher temperature than the skin (32°C to 35°C), it will heat the body rather than cooling it. At temperatures above 35°C, evaporative cooling becomes the main strategy for cooling, as evaporation is an endothermic process, and extracts the *latent heat* from the surroundings, to change water into vapor.

Subjective reactions to air movements can be categorized as follows :

*Table 2-B Subjective reactions to air movement (Source : Szokolay, 2008)*

Air Velocity (m/s)	Physiological reaction
< 0.1	Stuffy
Up to 0.2	Unnoticed
Up to 0.5	Pleasant
Up to 1.0	Awareness
Up to 1.5	Draughty
> 1.5	Annoying

**Humidity:** Relative humidity greater than 65%, restricts evaporation from the skin and respiration, thus reducing the dissipation mechanism, whereas low humidity's (less than 30%) can lead to drying out of the skin and mucous membranes (mouth, throat) thus causing discomfort.

**Radiation:** The body will lose heat if the surroundings are colder and gain heat if they are hotter. The radiation from heated surfaces in a room is invisible long-wave or infrared radiation.

Radiation exchange is dependent on the average temperature of surrounding surface elements, which is termed as the **Mean Radiant Temperature (MRT)**.

The MRT can only be measured by a black globe thermometer, which responds to radiant inputs as well as to air temperature. A matt black painted ping pong ball can be used to measure the globe temperature (GT). MRT can be measured by the expression (Szokolay, 2008):

$$MRT = GT \times \left(1 + 2.35\sqrt{v}\right) - 2.35 \times DBT\sqrt{v} \quad (4)$$

Where,  $v$  = air velocity (m/s)

#### 2.2.1.2 Personal Factors

**Metabolic Rate:** The metabolic rate is dependent on the activity level, measured as *met*, which is 58.2 W/m<sup>2</sup> of the body surface area.

The body surface area can be measured as :

$$A_D = 0.202 \times M^{0.425} \times h^{0.725} \quad (5)$$

(Du Bois & Du Bois, 1916)

For a normal activity level, and an average person of 80 Kg and 1.8 m height, metabolic rate would be 115 W, this will increase with activity levels.

**Clothing:** Clothing is treated as a uniform layer of insulation between the body and the environment having a single surface temperature ( $T_{cl}$ ). Thus, the overall insulation of the clothing can be expressed as the sum of individual clothing worn by a person. The air trapped between the multiple layers is accounted for in the overall clothing ensemble (Lotens & Havenith, 1989)

The units of measurement is **clo**, which means a U-value of 6.45 W/m<sup>2</sup>K (or a resistance of 0.155 m<sup>2</sup>K/W) over the whole body surface. This unit was introduced to keep an office worker, in a three-piece office suit and an underwear comfortable at 21°C (Nicol, Humphreys, & Roaf, 2014)

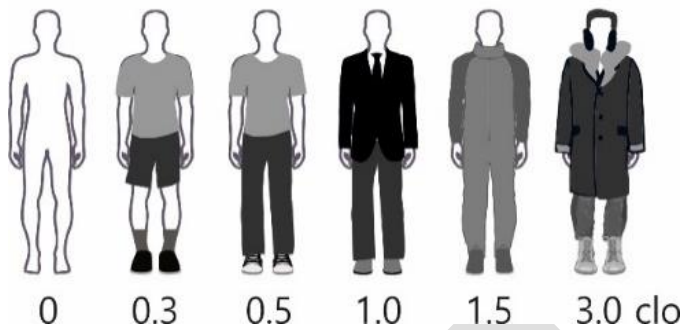

Figure 2-14 Figure showing the Clo values for different levels of clothing

### 2.2.1.3 Contributing Factors

The external factors like food and drink habits, body shape and subcutaneous fat will have an indirect effect on thermal preferences. These effects may change with time.

For e.g. a tall and skinny person will dissipate more heat easily, rather than a person with a more rounded body shape, as heat dissipation depends on body surface area. On the other hand, a person with more subcutaneous fat, will feel less cold, as it is a very good insulator.

### 2.2.2 Comfort Temperature Range

There are many thermal adjustment mechanisms in the body. In colder climate, *vasoconstriction* reduces the blood flow to the skin, reduces the skin temperature thus reducing heat dissipation. Whilst, in the warmer climate, *vasodilation* increases the blood flow to the skin, increasing the skin temperature and thus heat dissipation. If the body is not able to dissipate heat, *hyperthermia* will occur, leading to heat stroke. On the other hand, if the body is not able to retain heat *hypothermia* will set in leading to fatal consequences.

However, these adjustments are not just physiological, it also involves psychological aspects, i.e. accepting the prevailing conditions as 'normal'

Several studies have been done by Humphreys (1978), Auliciems (1981), Nicol and Roaf (1996). Based on the analysis of these studies, (Szokolay, 2008), showed that the '*neutrality temperature*' is dependent on the mean temperature of the month, and is expressed as:

$$T_n = 17.8 + 0.31 \times T_{o.av} \quad (6)$$

Where,  $T_{o.av}$  is the mean temperature of the month.

The comfort zone can be taken relative to the  $T_n$  for 90% acceptability as

$$T_n \pm 2.5^\circ\text{C} \quad (7)$$

For e.g. if the  $T_{o.av}$  is  $15^\circ\text{C}$  for the month of September for a place, the  $T_n$  will be  $17.8 + 0.31 \times 15 = 22.5^\circ\text{C}$ , and the comfort range will be from  $20^\circ\text{C}$  to  $25^\circ\text{C}$ .

Since, comfort is not a function of temperature alone, *effective temperature* indices were developed by Houghten and Yaglogolou (1927) to combine the effect of air temperature, air movement, humidity and radiation. The latest comfort index is the  $ET^*$  (ET star) or the **SET**.

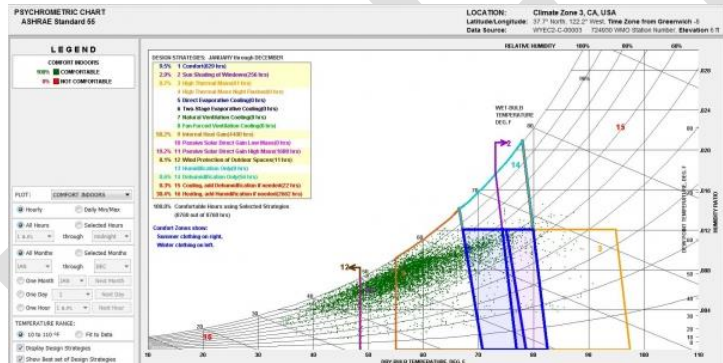

Figure 2-15 Example of a Psychrometric Chart (Source : Climate Consultant 6.0)

The SET isotherms are plotted on psychrometric chart, combining the effect of temperature and humidity, the two most important determinants.



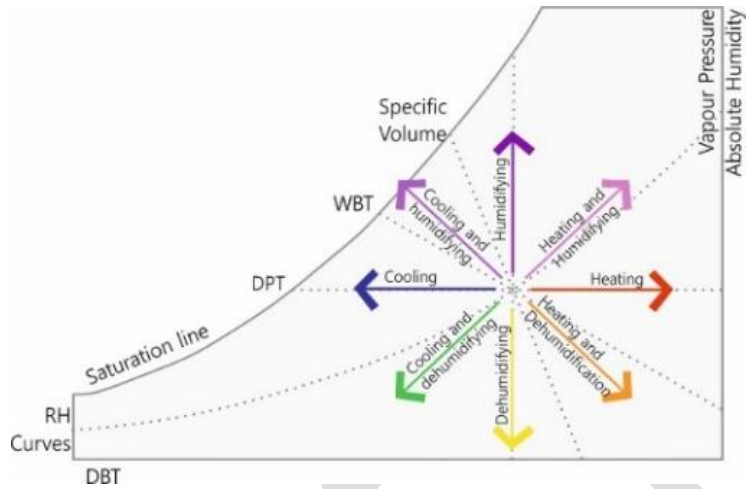

Figure 2-16 Status Point plotted on Psychrometric Chart

Psychrometric chart (Fig 1-16) is a useful graph for determining the thermal parameters of air. By measuring DBT (dry bulb temperature) and WBT (wet bulb temperature), it becomes easier to know the indoor as well as outdoor air conditions.

The status point represents the thermal comfort temperature (Fig 1-15). Strategies are devised accordingly, to understand the applicable air conditioning processes such as cooling, heating, humidification, dehumidification and combination of these

To plot the thermal comfort zone, first find the neutral temperature using Equation (6), for both the warmest and coldest period, taking comfort limits as  $T_n \pm 2.5^\circ\text{C}$ . Plot these on the 50% RH curve (Fig 1-16)

## 2.3 Visual Comfort

The Figure 2-17 shows the solar radiation spectrum. A narrow wavelength-band of electromagnetic radiation ranging between 380 nm to 780 nm, is perceived by our eyes as light (Szokolay, 2008)

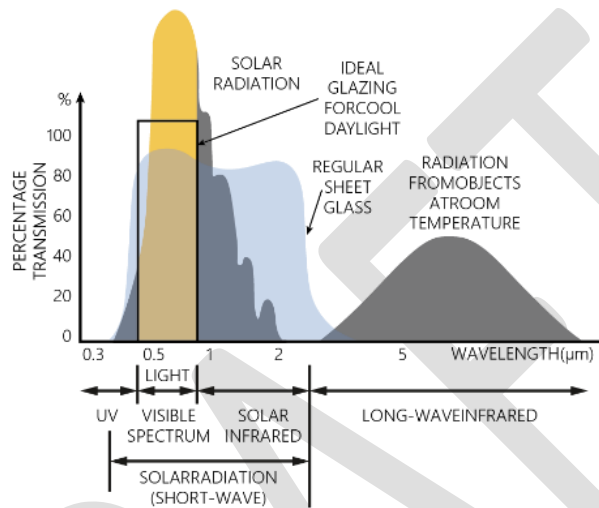

Figure 2-17 Solar radiation spectrum

Visual Comfort is that condition of human mind in which they feel satisfied due to a physical reaction between human eye and quantity & quality of light. The presence of daylight and views, and the contrast between task lighting and ambient lighting, combined with access to quality views, all play a role in our overall visual comfort. The concept of visual comfort depends on our ability to control the light levels around us. The visual comfort can be measured qualitatively as well as quantitatively.

### Qualitative aspects of light

- **Brightness:** Human beings judge brightness of an object relative to the brightness of the surroundings. To great extent, it depends on the adaptation of the eye.
- **Contrast:** It is the difference between the brightness of an object and that of its immediate background.
- **Glare:** Excessive contrast cause glare.

### Quantitative aspects of light

- **Luminous Flux:** Amount of light flowing through a space is called Luminous flux. Its unit is Lumens
- **Illuminance:** Light falling on a surface is called Illuminance. Its unit is lumens per unit area. (Lux)
- **Luminance:** Light reflected from a surface is called luminance (Cd/m<sup>2</sup>).

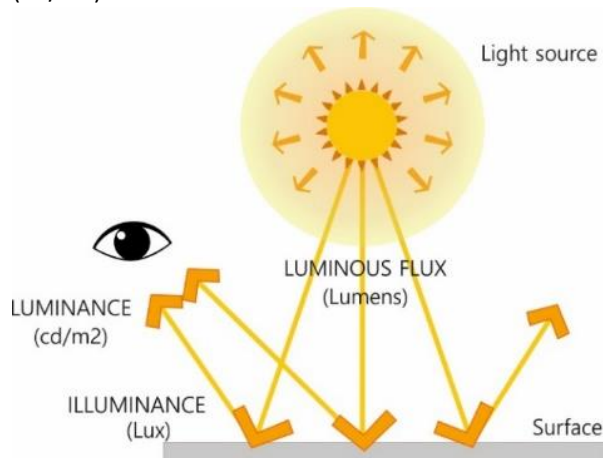

Figure 2-18 Figure explaining the difference between Luminance and Illuminance

Generally, a careful balance between natural and artificial lighting is recognized as the best way to ensure a comfortable experience.

ECBC 2017 prescribes the **Useful Daylight Index (UDI)** for visual comfort:

#### **Useful Daylight Index (UDI)**

It is defined as the annual occurrence of daylight between 100 lux to 2000 lux on a work plane. The daylight is most useful to occupants, glare free and when available, eliminates the need for artificial lighting

This can be analysed using simulation software or manually measuring the Daylight Extent Factor (DEF)

Apart from improving occupant productivity, it also helps in reduction in electrical load due to lighting energy demand.

## 2.4 HVAC System

Heating, Ventilation and Air Conditioning (HVAC) System is a combined process that conditions the air, transports it and introduces it to the conditioned space. It also controls and maintains the temperature, humidity, air movement, air cleanliness, sound level and pressure differential in a space within predetermined limits for the comfort and health of the occupants of the conditioned space or for the process of product processing.

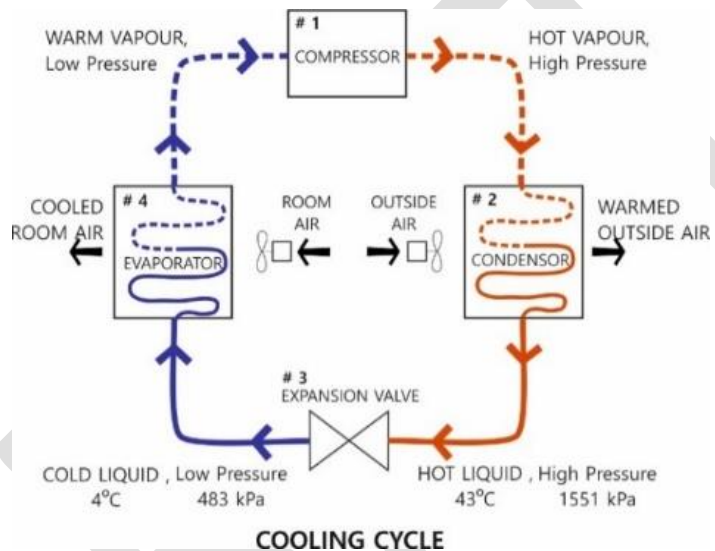

Figure 2-19 HVAC System- Cooling Cycle

There are seven main processes required to achieve desired thermal comfort and they are listed as below:

- a. Heating** – The process of adding thermal energy (heat) to the conditioned space for the purposes of raising or maintaining the temperature of the space.
- b. Cooling** – The process of removing thermal energy (heat) from the air-conditioned space for the purposes of lowering or maintaining the temperature of the space.
- c. Humidifying** – The process of adding water vapor (moisture) to the air in the conditioned space for the purposes of raising or maintaining the moisture content of the air.

**d. Dehumidifying** – The process of removing water vapor (moisture) from the air in the conditioned space for the purposes of lowering or maintaining the moisture content of the air.

**e. Cleaning** — The process of removing particulates (dust, etc.) and biological

contaminants (insects, pollen, etc.) from the air delivered to the conditioned space for the purposes of improving or maintaining the air quality.

**f. Ventilating**—the process of exchanging air between the outdoors and the conditioned space for the purposes of diluting the gaseous contaminants in the air and improving or maintaining air quality, composition, and freshness. It can be achieved either through natural ventilation or mechanical ventilation. Natural ventilation is driven by natural draft, like when you open a window. Mechanical ventilation can be achieved by using fans to draw air in from outside or by fans that exhaust air from the space to outside.

**g. Air Movement**—the process of circulating and mixing air through conditioned spaces in the building for the purposes of achieving the proper ventilation and facilitating the thermal energy transfer

There are different types of HVAC systems available, and it is important to understand which system is applicable for a project.

**System types include:**

- Direct expansion (DX) packaged systems
- Chilled Water Systems (air cooled and water cooled)
- Constant volume and variable air volume systems
- Computer room units (CRUs)
- Packaged terminal air conditioners (PTACs)
- Heating only systems
- Heating and Ventilation Systems
- Apart from these systems, there is also a range of low-energy active systems available:
  - Evaporative Cooling
  - Desiccant Cooling System
  - Solar air conditioning
  - Tri-generation (Waste to Heat)

- Radiant Cooling System
- Ground Source Heat Pump
- Adiabatic Cooling System
- These systems have been further described in Chapter 5

DRAFT

## 2.5 Energy Distribution in Commercial Buildings

The average energy performance index for commercial buildings is around 70 kWh/m<sup>2</sup>/year. The graph (Figure 2-20) summarizes the EPI distribution for various commercial building types, ranging from ~100 kWh/m<sup>2</sup>/annum in the public sector to 350 kWh/m<sup>2</sup>/annum in three shift commercial office buildings. (BEEP India, 2013).



Figure 2-20 Energy Performance Index of Commercial Buildings in India in 2013 (Source : BEEP India)

In a typical commercial building, the major share of energy is from Cooling, Equipment and Lighting (Figure 2-21)

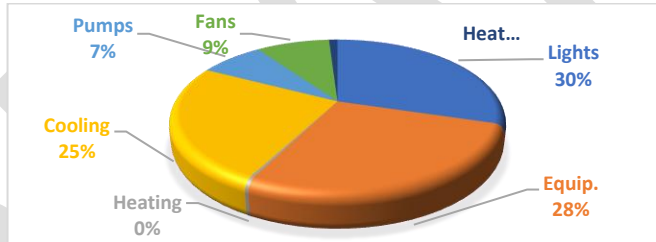

Figure 2-21 Energy Distribution in a typical office building (Source : EDS)

# Chapter 3. INTEGRATED DESIGN PROCESS

## INTENT

The chapter touches upon the process to be followed to design an energy efficient building. The various steps of the design process are elaborated as per its relevance and contribution to the design process and the tools to be used to perform the analysis.

## SECTION ORGANISATION

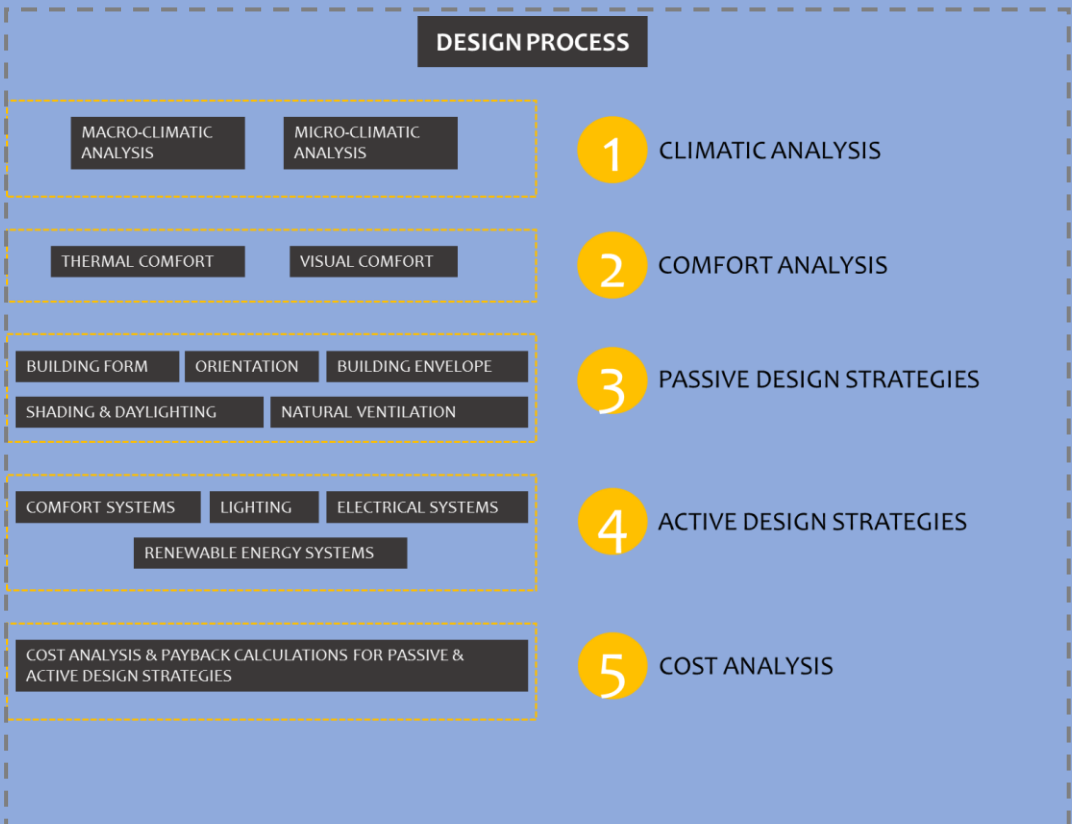



## 3.1 The Design Process

The process to design an energy efficient building is a step by step process:

### **Step 1 - Reduce thermal loads**

The loads that contribute to thermal loads in a building are a combination of external and internal loads.

Internal loads include occupant, lighting and equipment loads. While, there is no control over occupant loads, lighting and equipment loads can be reduced by using efficient lighting fixtures, good daylighting and controls over lighting. Similarly, equipment loads can be reduced by using efficient equipment's.

### **Step 2- Use low energy passive measures for heating/cooling**

The second step falls in the ambit of architects and planners. The passive measures pertain to having a good building envelope, efficient planning to reduce/increase thermal gains. It becomes increasingly important to understand how the building behaves, to apply the suitable passive measures for that climate

### **Step 3- Use highly efficient active systems for heating/cooling**

The comfort of the occupants is non-negotiable. The active systems compensate for what the building design and envelope is not able to cover. The appropriate system selection and efficient technologies further help in reducing the energy demand.

### **Step 4- Use Renewable Energy**

The fourth step is to utilize the natural resources available for renewable-energy generation to cover up the energy demand of the building/facility. The important step is to understand the climate and resources around the site, select the best source of available renewable energy-wind, solar, hydro-power or biogas and calculate the amount of energy that can be generated from the available space.

### **Step 5- Cost and Payback Analysis**

The step by step analysis will help, the architects and engineers in listing down the strategies, required to design an efficient building.

Based on the combined passive and active strategies, the savings in Annual Energy Demand (kWh) can be calculated and compared with the initial cost investment required to implement the strategies in the building.

The percentage of cost investment and savings in annual energy demand can be used to calculate the payback period of the strategies on the overall project cost.

DRAFT

## 3.2 Climatic Analysis

Climate is the most important environmental factor and the first one that architects, and engineers should consider when designing a building. The climate can dictate what passive design strategies are most suitable and effective for the building site.

For example, in a place like Chennai, one feels hot and perspires a lot because of two factors: high humidity and high solar radiation. The building design must cater to these two issues to reduce discomfort. On the other hand, in a colder place like Manali, it is beneficial to maintain warmth inside the building due to the predominantly cold climate. Hence, climate plays a pivotal role in determining the design of a building.

The climate of a place is largely dependent on the geographical location and altitude. However, the site surroundings also play a major role in impacting the micro-climate of the site.

To understand the climate of a place, it is important to analyze the climate at the macro and micro-levels.

### 3.2.1 Macro-Climatic Analysis

The factors that help in the climatic analysis process are as follows:

- Ambient temperature
- Solar radiation
- Humidity
- Sky Condition
- Precipitation
- Wind

**Weather Files** – The weather files are available in various formats. The most common being the Energy Plus Weather file (.epw) format.

The weather files contain annual hourly data of:

- Dry Bulb Temperature
- Dew point temperature
- Relative Humidity
- Atmospheric Station Pressure
- Extraterrestrial Horizontal Radiation
- Extraterrestrial Direct Normal Radiation

- Horizontal Infrared Radiation from sky
- Global Horizontal Radiation
- Direct Normal Radiation
- Diffuse Horizontal Radiation
- Global Horizontal Illuminance
- Direct Normal Illuminance
- Diffuse Horizontal Illuminance
- Zenith Luminance
- Wind Direction
- Wind Speed
- Total Sky cover
- Opaque Sky Cover
- Visibility
- Precipitation

**Processing Weather Files** – The weather files can be processed manually or through weather tools to analyze the climate of the site.

Graphs should be plotted to look at the monthly average temperatures, daily diurnal temperatures at peak days, temperatures against solar radiation to identify periods when shading is required, etc.

**Tools:** Climate Consultant, Weather Tool-Ecotect

WEATHER DATA SUMMARY												LOCATION: New Delhi-Safdarjung AP, DL, IND		
												Latitude/Longitude: 28.56° North, 77.2° East, Time Zone from Greenwich 5		
												Data Source: ISHRAE2014 421820 WMO Station Number, Elevation 216 m		
MONTHLY MEANS														
	JAN	FEB	MAR	APR	MAY	JUN	JUL	AUG	SEP	OCT	NOV	DEC		
Global Horiz Radiation (Avg Hourly)	328	423	513	537	524	464	401	404	451	424	379	327	Wh/hour.m	
Direct Normal Radiation (Avg Hourly)	428	510	592	525	455	241	255	252	379	462	453	432	Wh/hour.m	
Diffuse Radiation (Avg Hourly)	140	138	140	162	170	185	201	213	173	130	134	125	Wh/hour.m	
Global Horiz Radiation (Max Hourly)	764	901	1019	1067	1089	1115	1033	1043	1010	884	755	751	Wh/hour.m	
Direct Normal Radiation (Max Hourly)	1195	1310	1332	1043	1076	1062	947	1008	1057	1037	865	1147	Wh/hour.m	
Diffuse Radiation (Max Hourly)	300	275	294	451	472	473	472	460	445	400	319	282	Wh/hour.m	
Global Horiz Radiation (Avg Daily Total)	3532	4642	6100	6830	7046	6408	5495	5236	5225	4888	4313	3544	Wh/hour.m	
Direct Normal Radiation (Avg Daily Total)	4245	5362	7042	6548	6117	4767	3463	3290	4990	6078	4790	4418	Wh/hour.m	
Diffuse Radiation (Avg Daily Total)	1453	1526	1665	2066	2289	2560	2738	2772	2111	1700	1419	1279	Wh/hour.m	
Global Horiz Illumination (Avg Hourly)	29179	50179	63837	64936	62956	59499	48904	46833	50614	50958	44063	37883	lux	
Direct Normal Illumination (Avg Hourly)	25195	31170	35241	32762	27990	22620	14776	13971	19590	22734	20606	25582	lux	
Diffuse Illumination (Avg Hourly)	12	16	22	29	33	32	30	30	29	26	19	14	degrees C	
Dew Point Temperature (Avg Monthly)	7	9	11	12	16	20	24	25	24	17	12	9	degrees C	
Relative Humidity (Avg Monthly)	75	68	56	37	41	54	75	75	76	64	65	75	percent	
Wind Direction (Monthly Mode)	320	320	340	320	320	140	90	270	270	320	320	320	degrees	
Wind Speed (Avg Monthly)	0	0	0	0	0	0	0	0	0	0	0	0	m/s	
Ground Temperature (Avg Monthly of 3 Depths)	18	17	18	19	23	27	29	31	30	28	24	21	degrees C	

Figure 3- 1 Weather Data Summary for New Delhi, India (Source: Climate Consultant v6.0)



Figure 3- 2 Monthly diurnal averages of Dry Bulb Temperatures and Solar Radiation for New Delhi, India (Source: Climate Consultant v6.0)

### **3.2.2 Micro-Climatic Analysis**

The climate of a place may deviate due to various factors. While, growing urbanization contributes to the heat island effect, Terrain, Vegetation and Water bodies contribute positively by effecting the temperatures, humidity and wind speed.

### **3.2.3 Vegetation**

Vegetation plays an effective role in controlling the microclimate. Plants, shrubs and trees cool the environment when they absorb radiation for photosynthesis. They are useful in shading a part of the structure and ground for reducing the heat gain and reflected radiation. By releasing moisture, they help raise the humidity level.

Vegetation also creates different air flow patterns by causing minor pressure differences, and thus can be used to direct or divert the prevailing wind advantage.

Trees can be used as windbreaks to protect both buildings and outer areas such as lawns and patios from both hot and cold winds. The velocity reduction behind the windbreak depends on their height, density, cross-sectional shape, width, and length, the first two being the most important factors.

### **3.2.4 Water Bodies**

Water has a relatively high latent heat of vaporisation, it absorbs a large amount of heat from the surrounding air for evaporation.

Large waterbodies tend to reduce the difference between day and night temperatures because they act as heat sinks. Thus, sites near oceans and large lakes have less temperature variation between day and night, as well as between summer and winter as compared to inland sites. Also, the maximum temperature in summer is lower near water than on inland sites.

The wind flow pattern at a site is influenced by the presence of a large waterbody, wind flow is generated due to the difference in the heat storing capacity of water and land, and the consequent temperature differentials.

### 3.2.5 Terrain

The topographical map will reveal important aspects on site which includes steepest area and flattest area. A detailed contour map helps in understanding the slope which plays a big role in setting of a building.

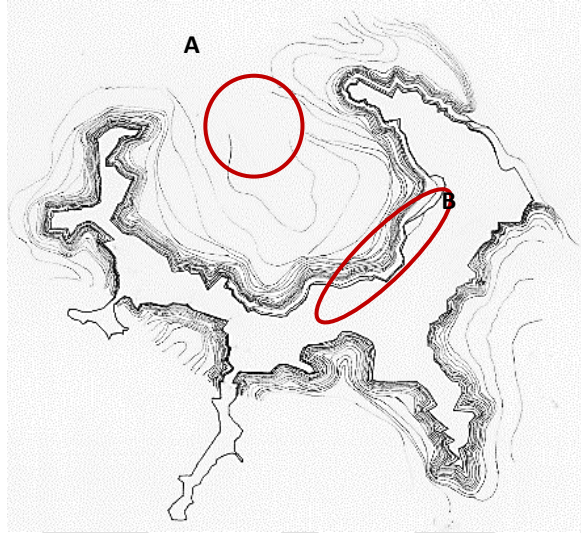

*Figure 3- 3 Typical Contour map (Source: ArcGIS)*

The above contour plan shows a lake and its surrounding areas. Each site has a unique nature of its own.

Point A in the above map shows the flattest area whereas Point B shows the steepest area.

A site suffers exposure to extreme climatic elements when it is directly affected by the full force of wind, water and sun (macroclimate conditions) without moderation from topographical constraints.

**Tools: ArcGIS software**

### 3.3 Comfort Analysis

The climatic analysis informs the designer on various passive design strategies that can be incorporated in the design to reduce the thermal loads from the building envelope.

It is equally important to understand the behavior of occupants and their comfort standards, as it varies from place to place, before the actual design process starts.

There are two aspects of comfort that need to be benchmarked for any project before starting the designing:

- Thermal Comfort
- Visual Comfort

#### 3.3.1 Thermal Comfort

Adaptive comfort models offer an opportunity to reduce energy use as buildings can be operated at more moderate temperatures. Operative temperatures for the model can be calculated using the formulae below (ECBC 2017).

##### 1. Naturally Ventilated Buildings

Indoor Operative Temperature:

$$(0.54 \times \text{outdoor temperature}) + 12.83$$

##### 2. Mixed Mode Buildings

Indoor Operative Temperature:

$$(0.28 \times \text{outdoor temperature}) + 17.87$$

##### 3. Air-Conditioned Building

Indoor Operative Temperature:

$$(0.78 \times \text{outdoor temperature}) + 23.25$$

Where indoor operative temperature (°C) is neutral temperature & outdoor temperature is the 30-day outdoor running mean air temperature (°C).

Tool: CARBSE has developed a Comfort and Weather analysis tool for major Indian cities based on the adaptive thermal comfort model.



### 3.4 Visual Comfort

Apart from defining the thermal comfort standards for the building, It is also important to determine the visual comfort requirements for the spaces in the building from the initial design stage. The Useful Daylight Illuminance (UDI) is a holistic analysis method measuring the useful daylight as well as glare on the work plane. (Fig 3-5)

The ECBC defines UDI between 100 to 2000 Lux as useful daylight.

The National Building Code 2016 also gives the minimum illuminance level (lux) applicable for different activities and spaces.

DRAFT

Table 3- A Recommended Values of Illuminance for some activities  
(National Building Code 2017, Part 8-Section 1)

Type of Interior or Activity	Range of Service Illuminance (lux)	Type of Interior or Activity	Range of Service Illuminance (lux)
<b>RETAIL</b>		<b>HOTELS</b>	
Small Shops	300-500-750	Bed Rooms	30-50-100
Super Markets	300-500-750	Entrance Halls	50-100-150
Shopping Precincts	100-150-200	Bars/Coffee Base	50-200
<b>PLACES OF PUBLIC ASSEMBLY</b>		<b>LIBRARIES</b>	
Public Rooms	200-300-500	General	200-300-500
Concert Halls		Reading Rooms	200-300-500
Auditorium	50-100-150	Bookshelves	100-150-200
<b>HOSPITALS</b>		<b>COMMERCE</b>	
General	200-300-500	General Offices	300-500-750
Consulting Areas	200-300-500	Computer Workstations	300-500-750
OT- General	300-500-750	Conference Rooms	300-500-750
OT- Local	10000-50000	Print Rooms	200-300-500
<b>EDUCATION</b>		<b>GENERAL BUILDING AREAS</b>	
Assembly Halls	200-300-500	Entrance Halls	150-200-300
Lecture Theatres	200-300-500	Corridors	50-100-150
Laboratories	300-500-700	Control Rooms	200-300-500
Sports Hall	200-300-500	Mechanical Plant Rooms	100-150-200

### 3.5 Passive Design Strategies

After scrutinizing the weather data and setting the benchmark for thermal and visual comfort, it is important to revisit the weather data, and identify days where thermal comfort standards are met and days where additional passive measures will be required to bring the temperatures to comfort zone.

This analysis can be done by overlapping the weather data graphs with the operative temperature (conditioned buildings) and parallelly identifying strategies from psychrometric charts.

For Example in Figure 3- 2, the annual dry bulb temperatures were plotted for New Delhi on the primary axis and global and horizontal radiation plotted on the secondary axis, to identify the periods where temperatures do not meet the operative temperatures setpoints and periods where direct radiation is high. Based on this information the passive design strategies can be identified, i.e. periods when cooling, shading, heating is required.

The effectiveness of each strategy (Figure 3- 5) was further analyzed from studying the psychrometric chart and selecting each strategy to identify its individual impact

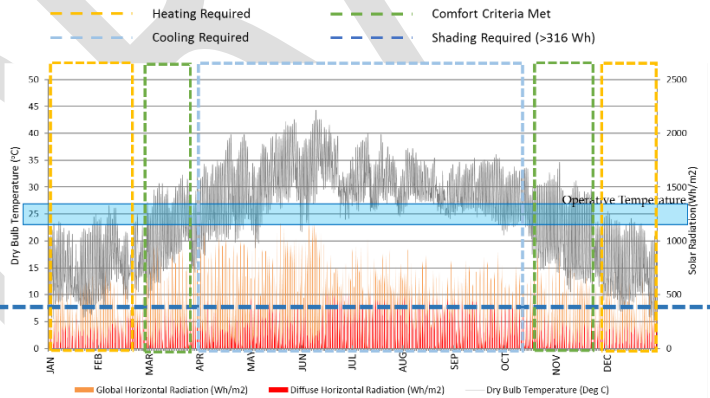
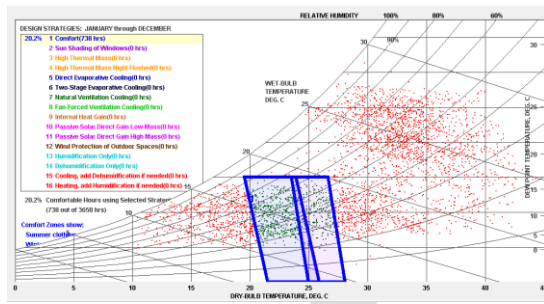

Figure 3- 4 Graph identifying periods of comfort and periods for which shading is required for New Delhi

**Comfort Zone – 738 Hours (20%)**



The Comfort Zone is assumed to enclose the number of hours when the occupants of a space are thermally comfortable whether in indoor or outdoor conditions

**Strategy 1- Sun Shading – 2099 Hours**

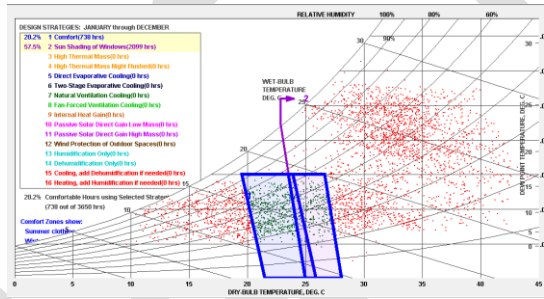

The Chart shows the number of hours when it is assumed that Sun Shading is provided, but these hours are not added to the total number of comfortable hours because shading by itself cannot guarantee comfort.

**Strategy 2- High Thermal Mass Night Flushed – 616 Hours (17%)**

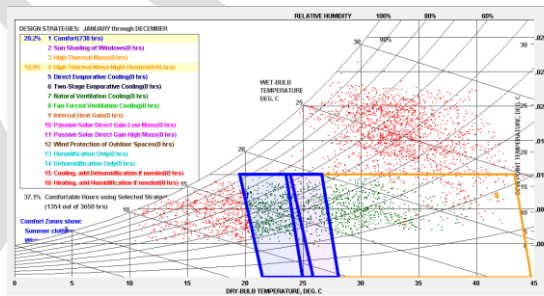

High thermal mass is a good cooling design strategy, especially when either natural ventilation or a whole house fan is used to bring in a lot of cool night time air and then the building is closed up during the heat of the day.

**Strategy 3-  
Direct  
Evaporative  
Cooling –  
526 Hours  
(14%)**

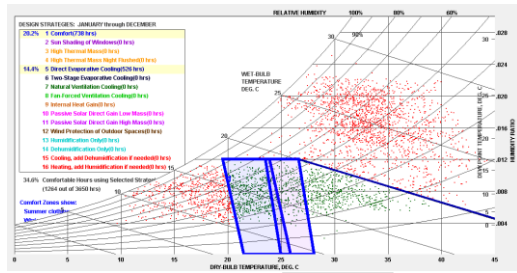

Evaporative cooling takes place when water is changed from liquid water to gas (taking on the latent heat of fusion), thus the air becomes cooler but more humid. Evaporation follows the Wet Bulb Temperature line on the Psychrometric Chart..

*Figure 3- 5 Passive Design Strategies to reduce thermal loads, analyzed from Psychrometric Chart for New Delhi (Source Climate Consultant 6.0)*

The impact of the various passive design strategies can be tested through shoebox energy modelling<sup>1</sup>

Shoebox modelling is a good practice in the energy modelling process, as it helps the architects/engineers to take informed decision on what passive measures to integrate in the building design.

By plotting the graphs, the linear relation between the two can be determined, informing the architect/designer on what strategy or combination of strategies, will be most effective in reducing the total energy consumption.

For Example, in Figure 3- 6, shoebox analysis was done for an office building in New Delhi to compare the impact of increasing the insulation in a heavyweight wall and a light weight wall. It was observed that in both the cases the increase in thermal insulation had a linear relation to the reduction in total energy consumption.

<sup>1</sup> [www.usgbc.org/education/sessions/shoebox-energy-modeling-6117518](http://www.usgbc.org/education/sessions/shoebox-energy-modeling-6117518)

On plotting the linear relationship between U-value and total energy consumption, it was observed that the light weight walls, due to less thermal mass, have a steeper slope compared to the heavy weight walls

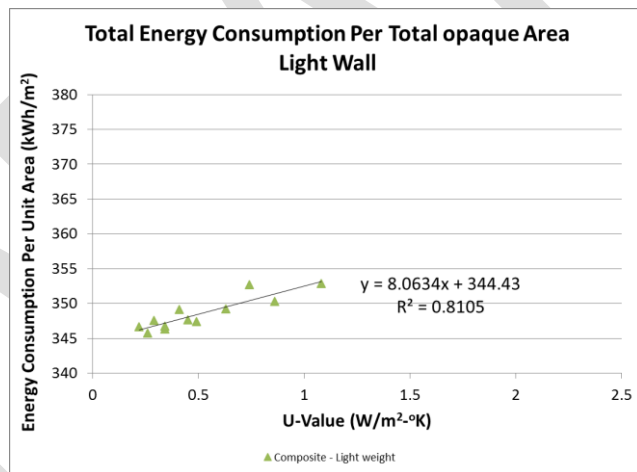
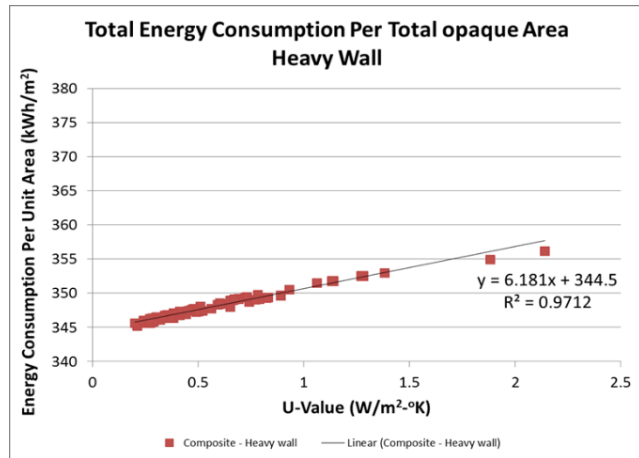

Figure 3- 6 Graphs showing impact of variation in U-value and SHGC on the Total Energy Consumption per Unit Area for New Delhi

## 3.6 Active Design Strategies

The passive design strategies help in reducing the thermal loads. For periods when the thermal comfort criterion is not met. Active Cooling or heating will be employed to bring those hours within the comfort zone.

There are various HVAC Systems available as discussed in Chapter 2.

### **HVAC System Selection**

The size of the project is a key component when choosing the HVAC System. For example, in a smaller project, it is preferable to choose DX systems due to lower initial cost and easy maintenance. For bigger projects, where cooling capacity is over 100 tons, the energy saving benefits of a chilled water system outweighs the initial cost and maintenance savings over a DX system.

The type of project also plays an important role in selection of the HVAC System, the HVAC system of an office building will be different than that of a shopping mall or retail store.

### **HVAC System Sizing**

The HVAC System sizing is a critical aspect of efficient HVAC design. Oversizing the system may lead to improper dehumidification of the space. If the system is undersized, it may not be able to maintain the required space conditions for part of the cooling or heating season.

Energy simulations and HVAC load calculations should be done to model the building as close to reality to get realistic figures and size the system accordingly.

The ECBC 2017 recommends the following strategies to reduce active cooling/heating loads:

- Demand Control Ventilation
- Efficient Systems- Pumps, Economizers, Cooling Towers
- Controls – Timeclock, Temperature, Occupancy, Fan and Dampers
- Centralized Demand Shed Controls
- Supply Air Temperature Reset

- Chilled Water Temperature Reset
- Piping and Ducting insulation
- System Balancing

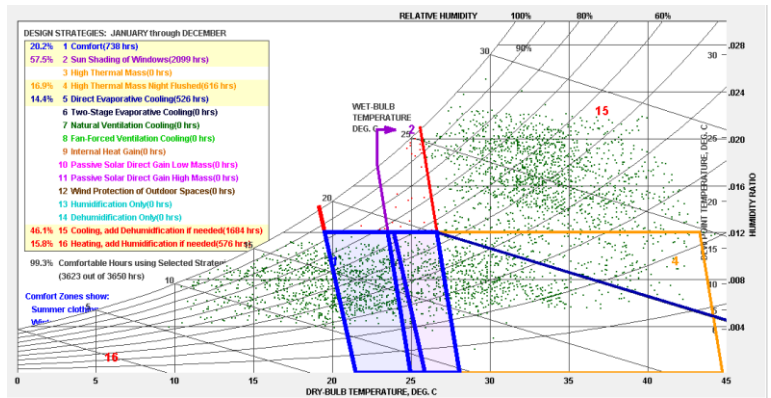

Figure 3- 7 Psychrometric Chart showing the percentage of time active cooling and heating is required after implementing the passive design measures (Source: Climate Consultant 6.0)

Apart from the HVAC Systems, there are other systems that contribute to the energy use of the building:

- Lighting Systems – Interior and Exterior
- Equipment's
- Transformers
- Motors
- DG Sets, UPS
- Renewable Energy Systems

Similar to the process of shoebox modelling for passive design strategies, the active design strategies should be tested to measure their impact on the Energy consumption. For example, for an office building in New Delhi, having an efficient building envelope and a radiant cooling system, active design strategies were incorporated to reduce the energy consumption. The measures were replacing the Constant Air Volume AHU to Variable Air Volume (VAV) AHU and replacing the Chiller with an efficient Chiller. These measures resulted in a total saving of 07% as seen in Figure 3-8.



Potential savings can be obtained from the lighting systems. Some of the design measures can be:

- Efficient Lighting Design
- Selecting Lighting with high efficacy
- Lighting controls – Daylight Sensors, Occupancy Sensors

Equipment's contribute almost 20% to the total energy consumption. Efficient Equipment's should be selected to reduce the energy consumption. BEE has a star rating system to categorize equipment's as per efficiency. Efficiency of the other systems contributing to energy consumption has been provided in the ECBC 2017.

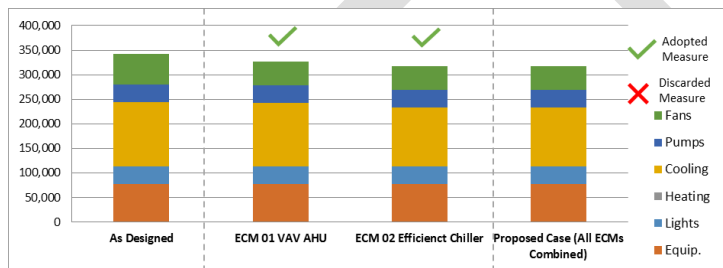

Figure 3- 8 Graph showing the impact of different active design measures on Annual Energy Use (kWh/m2/Yr)

### 3.7 Cost Analysis

The last and critical step is to perform the cost and payback analysis to ensure that the investments in incorporating the various passive and active strategies do not escalate the project cost unrealistically and have a reasonable payback period.

#### Lifecycle Cost Analysis and Net Present value

The life cycle cost model is used to identify all the reasonable envelope products or systems that are applicable, and analyze the one that is most cost effective.

#### 3.7.1 Formula:

The LCC is calculated based on the initial cost, i.e. the construction cost to install that material and the net present value of all the energy savings made through the respective measures. The initial cost includes material cost, labor cost, and construction cost.

#### 3.7.2 Energy price calculation

Assuming the national average energy cost was ₹ 9.50 per unit with a demand charge of ₹ 140/ kW. Based on national average electricity charges, per unit charge (₹ / kWh) and the demand charge (₹ / kW) were taken and included into simulation software (eQuest). The software calculates the final tariff rates based on the demand from the building (Table 3-B).

Table 3- B Final Tariff rates (national average) – small office building

	National average electricity rate (₹ /kWh)*
Energy rate per unit	10.31
PV for 10 years	98.26
PV for 20 years	163.70
PV for 30 years	202.08

\*at a discount rate of 3%

As per the per unit energy rate estimated, Net Present Value (NPV) of the total cost paid for per unit electricity is estimated

for a period of 10 years, 20 years, and 30 years at a discount rate of 3%. ECMs were considered economically viable if they could save 1 kWh of electricity for an additional cost (in reference to the baseline specification) less than the estimated NPV value. For example, targeting a return of 30 years, any ECM which could save 1 kWh of electricity for an additional cost of ₹ 202.08 compared to the baseline specification of that category is economically viable.

A graph (Figure 3- 9) was plotted to understand the trend of U-value of wall construction with LCC, initial cost, and NPV of savings. The trend of NPV of savings is observed to be linear, i.e. with decreasing U-value, the NPV of over savings increases linearly. However, trend of initial cost and LCC against U value is polynomial. The cost of constructing a wall assembly with a U value less than of  $0.3 \text{ W/m}^2\text{-K}$  rises steeply resulting in no significant reduction in LCC after the U value of  $0.3 \text{ W/m}^2\text{-K}$ .

Further to understand the LCC analysis, another graph (Figure 3-10) was plotted to understand the trend of payback period and internal rate of return (IRR). It was observed that in a composite climate, the U value of 0.4 W/m<sup>2</sup>-K performs best in terms of payback and IRR

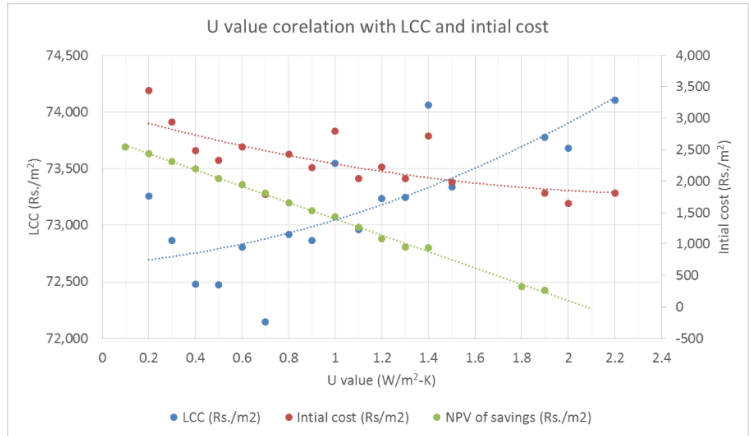

Figure 3- 9 Graph showing U-value correlation with LCC and Initial Cost

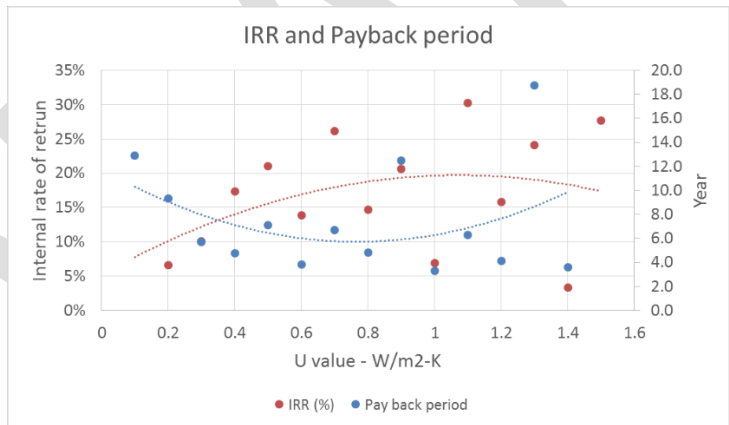

Figure 3- 10 Graph showing IRR and Payback Period

# Chapter 4. PASSIVE DESIGN STRATEGIES

## INTENT

An important step in optimizing a building design for energy efficiency is through passive design measures. These strategies include site planning as well as building design. The general design strategies pertain to orientation, building form and layout, shading, daylighting and natural ventilation. The strategies that are specific to the building use and typology revolve around the building envelope design.

## SECTION ORGANIZATION

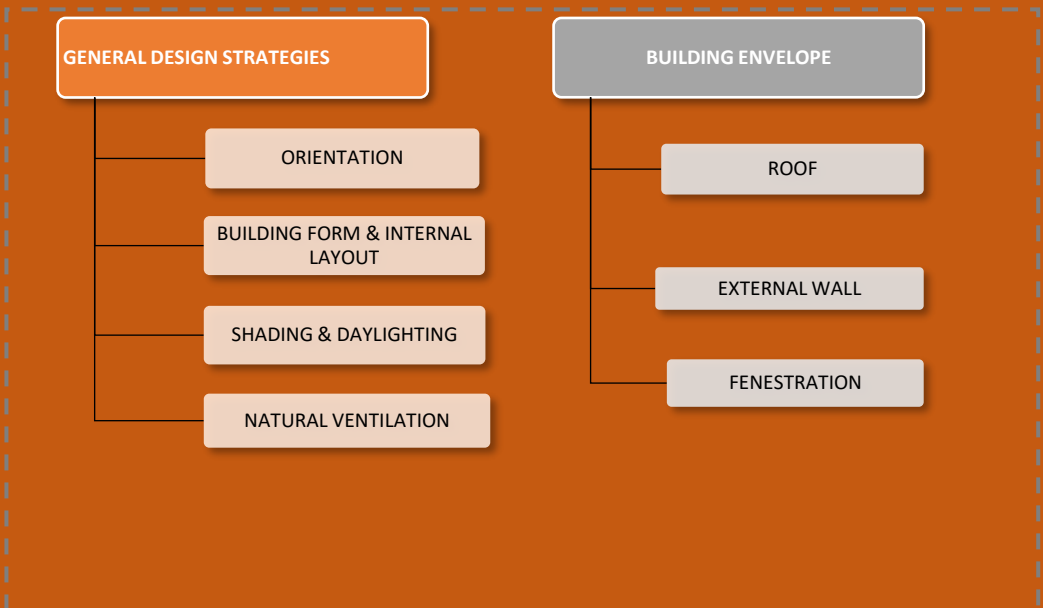

## 4.1 General Design Strategies

### 4.1.1 Orientation

In the hot and dry climate zones, the optimum orientation is north-south, however there are many factors that contribute in determining the best orientation. In this climate, protection from the sun is the most important strategy, and the amount of solar radiation incident on different facades helps to determine the best orientation.

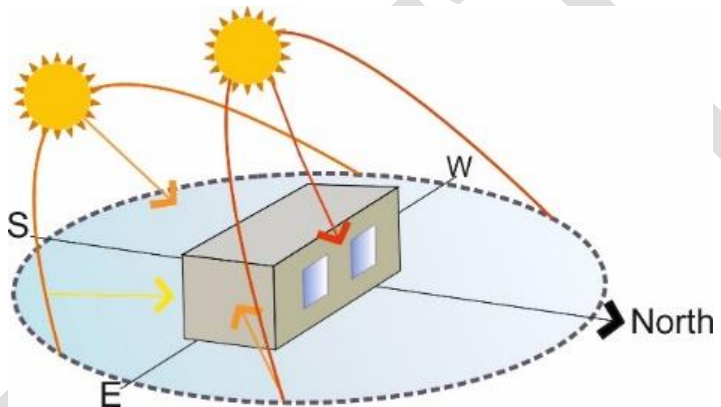

*Figure 4- 1 Orientation of buildings in composite climates, to reduce summer solar gains and increase winter solar gains*

Analyzing the precedents, buildings perform best when arranged in clusters as the building gets shaded by neighboring buildings.

The other determining factor is wind. The buildings should be oriented facing the prevailing cool wind direction to allow maximum cross ventilation during the night, and avoid hot dusty winds during the day.

In majority of the cases there can be a contradiction in determining the orientation due to the sun and wind. A detailed analysis of the specific situation should be conducted, and strategies for diverting the wind direction by planting vegetation or structural interventions should be considered.

In areas facing winter conditions, the orientation should also allow maximize passive heat gains during the winters

The warm-humid climate zones experience more solar radiation concentrated on the East and West slope. Therefore, the building should be oriented facing away from the equator, preferably on the northern or southern slopes.

The sites should be on the windward slopes near the crest or near the beach.

In the case of low rise buildings, the exposed wall area is less, receiving lesser radiation, here, orientation due to wind direction is advisable, whereas for taller buildings, protection from the sun will play the key role.

The moderate climate zones are generally located on hilly or high plateau regions, the primary design criteria is to reduce heat gain. Therefore, the building should be oriented with the longer axis facing north-south.

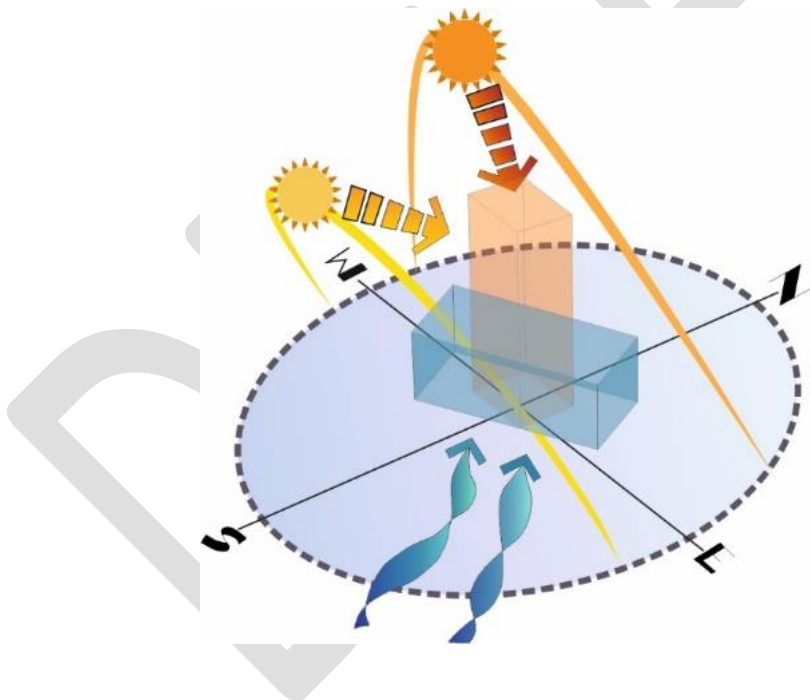

*Figure 4- 2 Different aspect ratios and impact of solar radiation*

The building should face the prevalent wind condition for adequate cross-ventilation.

#### 4.1.2 Building Form and Internal Layout

The main strategy in this climate is protection from the sun and good ventilation. Forms with larger surface areas will provide more openings for ventilation and heat emission during the night, however, the building should not have a large surface to volume (S/V) ratio to minimize heat gains. The buildings will perform better if arranged in row houses, group arrangements or with adjoin houses to create a volumetric effect.

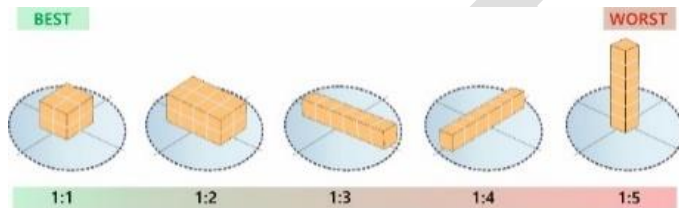

Figure 4- 3 Optimum S/V ratio to minimize heat gains

The internal layout is dependent on the orientation and building function-specific. For commercial buildings, the major contribution to heat loads is from the occupants and equipment's. As a rule of thumb, the rooms should be arranged according to their function and the time of the day they are used.

For hot and dry climate, rooms thermal barriers should be created on the east and west side of the building by placing non-habitable spaces in these orientations.

The spaces should preferably be inward looking, with minimal exposure to the sun

For warm and humid climate, rooms on the east side should be used during the afternoon and rooms on the west side during the morning hours.

Spaces on the North and south remain relatively cool, due to the high angle of sun in these orientations, but adequate shading needs to be provided.



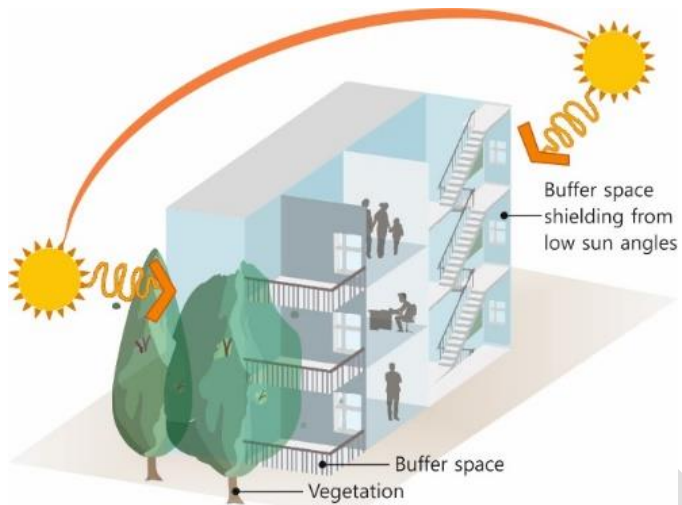

*Figure 4- 4 Internal Layout of spaces to reduce solar gains*

For spaces with higher humidity levels proper cross-ventilation should be provided to avoid mold growth.

Buildings should have narrow floor plates for optimized cross ventilation and daylighting. The building roof should serve the dual function of protection against precipitation, as well as shading. Building should be detached and elevated from the ground to allow ventilation.

In the cold climates, the main criteria for design is to retain the heat in the building by using insulation and reduced infiltration. In addition, passive measures should be taken to trap the incoming solar radiation by orienting the building towards the south, east and west. Buffer spaces should be given on the North orientation which does not receive any solar gains. The building should be sealed and preferably facing away from the cold winds

### **4.1.3 Shading and Daylighting**

Shading of direct sun and its reflection in the surrounding is important. Shading can be through neighboring buildings, self-shading from the building shape, vegetation or special shading devices such as louvers or perforated screens, lattices, grills, etc. will be required on the East and West façade to protect against the low sun angles, high intensity solar radiations and direct

glare. Internal spaces can also be shaded using gallery or balcony spaces.

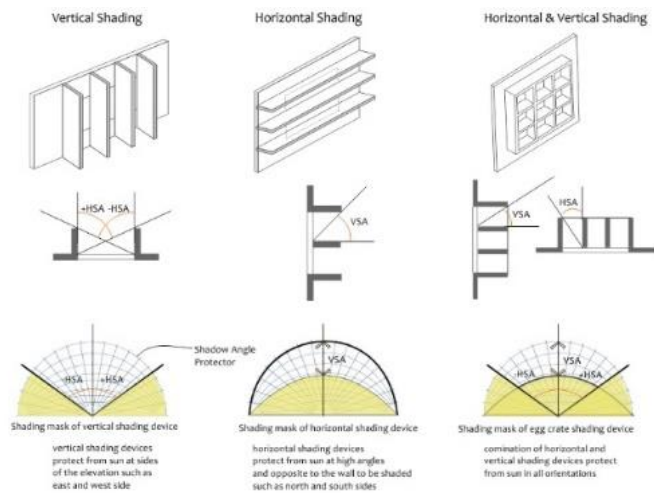

Figure 4- 5 Shading Design strategies

Special shading devices such as louvers or perforated screens, lattices, grills, etc. will be required on the East and West façade to protect against the low sun angles, high intensity solar radiations and direct glare. The north and South facades can be protected by an overhang.

The North façade gets exposed to the sun only during the monsoons, when it is predominantly overcast, thus, shading is not required. A simple overhang is adequate to block the sun in the south orientation. The East façade requires boxed shading, whereas, Special shading devices such as louvers or perforated screens, lattices, grills, etc. will be required on the West façade to protect against the low sun angles, high intensity solar radiations and direct glare. The north and South facades can be protected by an overhang.

#### 4.1.4 Natural Ventilation & Evaporative Cooling

For Hot and dry climates, ventilation is required, but care should be taken to avoid hot dusty winds during the daytime and providing ventilation during the night time, possibly filtering it through vegetation.

The building should be placed with openings towards the prevailing wind. The building should have large openings, both

on the facade as well as the space planning. An efficient strategy can be to have single-banked spaces with access to open areas or galleries.

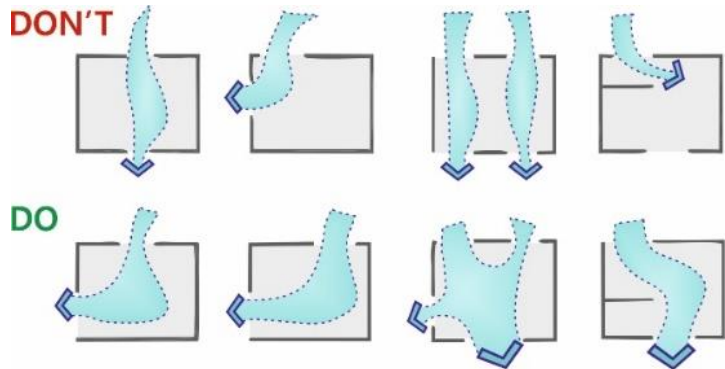

Figure 4- 6 Effective Strategies for cross-ventilation

Evaporative cooling can be an effective strategy in reducing the cooling loads, at least during the shoulder months.

In warm and humid climates, ventilation is required to control the high humidity and warm temperatures.

The building should be placed with openings towards the prevailing wind. The building should have large openings, both on the facade as well as the space planning. An efficient strategy can be to have single-banked spaces with access to open areas or galleries.

There should be large openings on both sides of the space to allow cross-ventilation. These openings can be protected using mosquito nets, louvers, lattice or grill, but glass panes should be avoided.

## 4.2 Building Component Strategies

### 4.2.1 Roof

The hot and dry regions are synonymous with high direct solar radiation. The roof is generally flat with large exposure to the sun; therefore, it becomes essential to minimize solar gains.

Since the diurnal difference in temperatures is significant, it is important to use high thermal materials, with high thermal capacity and high reflectivity to reflect the solar radiation.

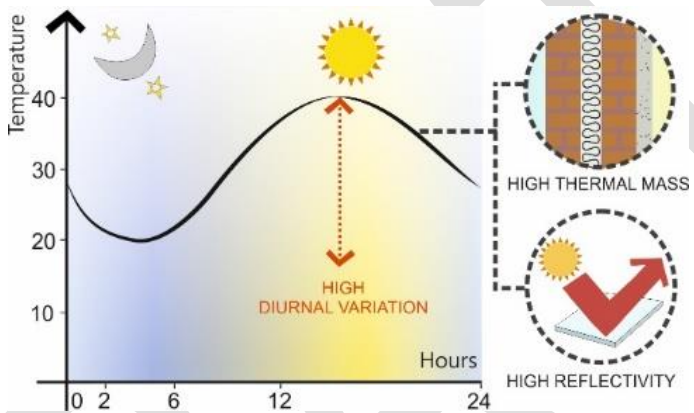

*Figure 4- 7 Building envelope strategies for areas with high diurnal variation*

The warm humid regions face high precipitation. The roof is generally pitched with large overhangs to allow easy run-off of rainwater, and, protect the building from solar radiation and precipitation.

Since the diurnal difference in temperatures is insignificant, it is important to use lightweight materials, with low thermal capacity and high reflectivity to reflect the solar radiation.

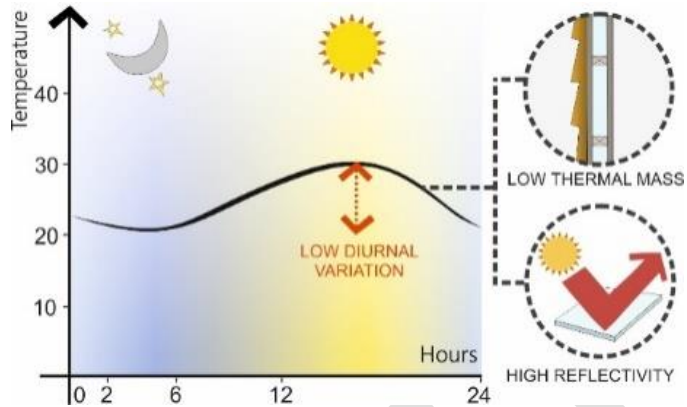

Figure 4- 8 Building envelope strategies for areas with low diurnal variation

The moderate regions experience high precipitation during the monsoons. The roof is generally pitched with large overhangs to allow easy run-off of rainwater, and, protect the building from solar radiation and precipitation.

It is important to use heavyweight materials, with high thermal capacity and high reflectivity to reflect the solar radiation, as the diurnal difference in temperatures is significant.

Some of the effective design strategies can be:

#### 4.2.1.1 Cool Roofs

A high reflective and light-colored roof can be an effective strategy in minimizing solar gains by reducing the roof surface temperatures. A cool roof can remain almost 38°C cooler than a traditional dark roof (NZEB). A cool roof coupled with insulation can provide higher savings.

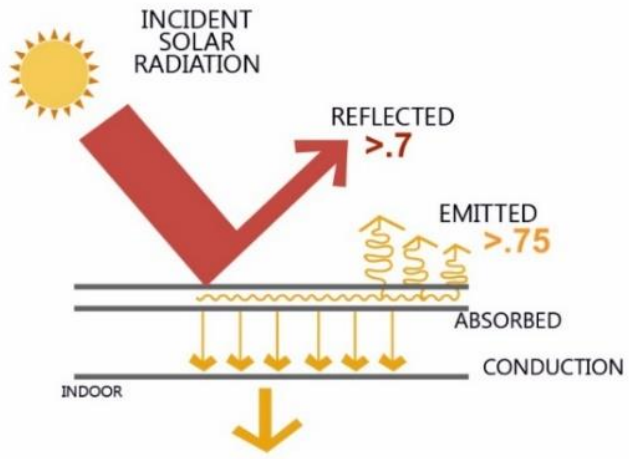

Figure 4- 9 Working of a cool roof

#### 4.2.1.2 Green Roofs

The green cover over roofs function as a second skin having significant insulation due to its composition. It helps in protecting the roof surface against direct solar radiation, and there is also regulating effect on humidity. and ambient temperature

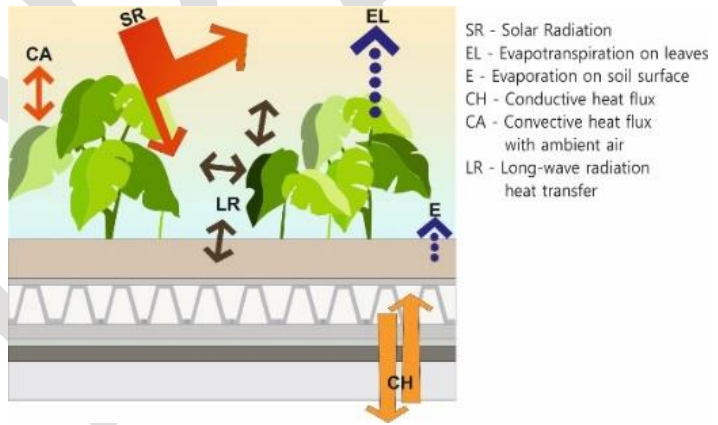

Figure 4- 10 Working of a green roof

#### 4.2.1.3 Ventilated Double Roof

A properly ventilated double roof can be an efficient solution compared to a single leaf roof construction. A double roof allows the movement of hot air, therefore reducing the warming of adjoining spaces due to convection.

#### 4.2.2 External Wall

In the hot and dry climate there is high variation in diurnal temperatures, therefore it is possible to achieve significant cooling by using thermal mass (Figure 4- 7), using materials with appropriate time lag. A double wall with sandwiched insulation can be an effective solution

It is recommended to use high thermal mass-weight wall assemblies to absorb heat over the day and take maximum benefit of night time cooling. The outer surface of the wall should be reflective, light colored and shaded as much as possible.

In the warm and humid climate zones, there is minimal variation in diurnal temperatures, therefore it is not possible to achieve much cooling by using thermal mass (Figure 4- 8). A relatively short time lag of about 5 hours may be adequate. On the other hand, constructions with high thermal storage capacity and long-time lag will result in undesirable re-radiation of heat at night.

It is recommended to use light-weight wall assemblies to dissipate heat quickly and take maximum benefit of night time cooling. The outer surface of the wall should be reflective, light colored and shaded as much as possible.

Like hot and dry climate, moderate climate zones receive significant variation in diurnal temperatures, therefore it is possible to achieve cooling by using thermal mass.

#### 4.2.3 Fenestration

The fenestration would fulfill two functional requirements, i.e. daylighting and natural ventilation. To allow cross-ventilation, it is preferable to have large opening towards the wind direction, however, the window to wall ratio, should be restricted to 40% as per ECBC to avoid glare and overheating.

DRAFT



# Chapter 5. ACTIVE DESIGN STRATEGIES

## INTENT

The intent of the chapter is to understand the active mechanisms and controls which contribute to the energy efficiency of the building and strategies that can be employed to improve their efficiency

## SECTION ORGANIZATION

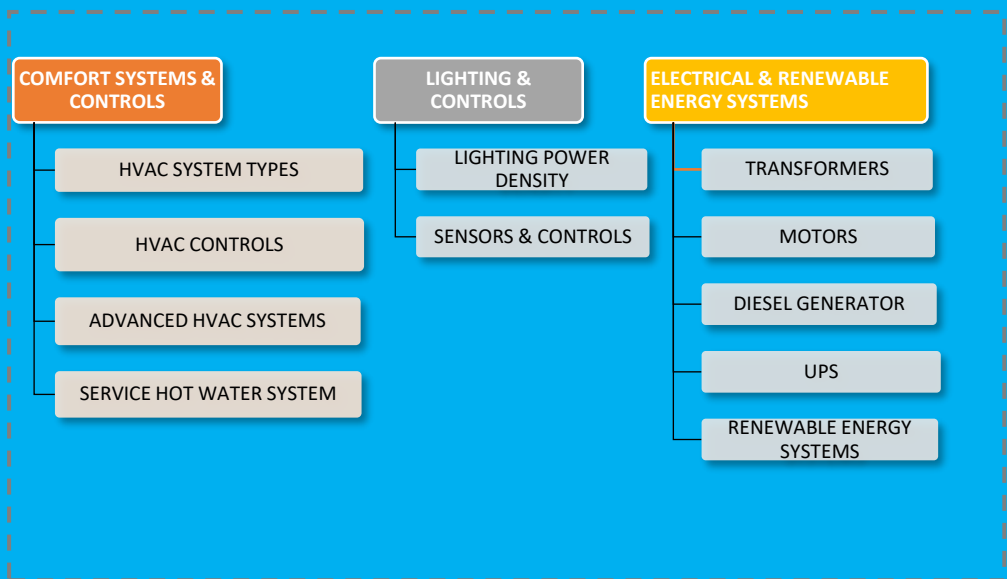

## 5.1 Comfort Systems and Controls

### 5.1.1 HVAC System Types

HVAC System types include:

#### **Direct expansion (DX) packaged systems**

##### 5.1.1.1 Unitary Air-conditioners

These systems serve a single, temperature-controlled zone. Mostly, found in small shops or residential rooms where the environment and usage generally remain the same.

##### 5.1.1.2 Split Air-conditioners

The system consists of an outdoor unit containing outdoor-air and return-air dampers, a compressor, controls, and an air-cooled condenser., and, an indoor system that has the fans, filters, a heating source, and a cooling coil. These systems are available in fixed increments of capacity.

A separate packaged heat pump unit (or split heat pump fan-coil) is used for each thermal zone.

Some systems may also contain a heating mode, provided by reversing the refrigeration circuit to operate the unit as a heat pump to be supplemented by electric resistance heating if heat pump heating capacity is reduced below required capacity by low exterior air temperatures.

Split systems have the indoor unit or units located indoors or in an unconditioned space and the condensing unit located outdoors on the roof level.

Performance characteristics vary among manufacturers, and the selected equipment should match the calculated heating and cooling loads (sensible and latent), also taking into account the importance of providing adequate dehumidification under part-load conditions

The fan energy is included in the calculation of the energy efficiency ratio (EER) for heat pump equipment, based upon standard rating procedures of IS 8148.

### 5.1.1.3 Packaged Air-conditioners

A packaged air conditioner has the evaporator, condenser, and compressor one cabinet, which is usually placed on the roof or overhang. The system consists of an air supply and return ducts for fresh air supply. The system often includes electric heating coils or a natural gas furnace, eliminating the need for a separate furnace indoors.

The equipment should be certified under BEE's Star Labelling Program

*Table 5-A Minimum Requirements for Unitary, Split, Packaged Air Conditioners in ECBC Building*

Cooling Capacity (kW <sub>r</sub> )	Water Cooled	Air Cooled
≤ 10.5	NA	BEE 3 Star
> 10.5	3.3 EER	2.8 EER

*Table 5-B Minimum Requirements for Unitary, Split, Packaged Air Conditioners in ECBC+ Building*

Cooling Capacity (kW <sub>r</sub> )	Water Cooled	Air Cooled
≤ 10.5	NA	BEE 4 Star
> 10.5	3.7 EER	3.2 EER

*Table 5-C Minimum Requirements for Unitary, Split, Packaged Air Conditioners in SuperECBC Building*

Cooling Capacity (kW <sub>r</sub> )	Water Cooled	Air Cooled
≤ 10.5	NA	BEE 5 Star
>10.5	3.9 EER	3.4 EER

### 5.1.1.4 Chilled Water Systems

A chiller is essentially a packaged system, which produces chilled water for cooling. Chillers are expensive and consume significant amounts of energy in commercial buildings, therefore, correct maintenance & operation is important.

The efficiency of a chiller is measured in terms of its COP or EER, both referring to the efficiency at full load conditions.

Since chillers mostly operate at part load conditions, the integrated part load value (IPLV) gives a more realistic indication of chiller performance. For instance, a large chiller operating after-hours to serve a small load such as a lift motor room or a computer room is likely to perform very inefficiently. The efficiency of a chiller depends on the technology used in the chiller, and, classified according to the compressor type. The electric chillers for commercial comfort cooling have centrifugal, screw, scroll, or reciprocating compressors.

- Centrifugal chillers are the quiet, efficient, and reliable workhorses of comfort cooling. Centrifugal types of compressor are the most efficient and were only available in large chillers until the advent of the magnetic bearing 'TurboCor' type. The chillers available are as small as 70 tons, but, mostly 300 tons or larger.
- Screw type compressors are used in medium size machines and are up to 40% smaller and lighter than centrifugal chillers, so are becoming popular as replacement chillers.
- Scroll compressors are rotary positive-displacement machines, also fairly new to the comfort cooling market. These small compressors are efficient, quiet, and reliable. Scroll compressors are made in sizes of 1.5 to 15 tons.

The efficiency of chillers has increased drastically due to advances in compressor technology, improvements to heat exchangers (evaporators and condensers) and better control of compressors using microprocessor technology and advanced control algorithms.

### 5.1.1.5 Air-Cooled Chilled Water Systems

For an air-cooled chiller, condenser fans move air through a condenser coil. As heat loads increase, water-cooled chillers are more energy-efficient than air-cooled chillers. A typical chiller is rated between 15 to 1000 tons (53 to 3,500 kW) in cooling power.

Table 5-D Minimum Energy Efficiency

#### Requirements for water cooled Chillers

	ECBC Building		ECBC+ Building		SuperECBC Building	
	COP	IPLV	COP	IPLV	COP	IPLV
Chiller Capacity (kW <sub>r</sub> )						
<260	4.7	5.8	5.2	6.9	5.8	7.1
≥260 & <530	4.9	5.9	5.8	7.1	6.0	7.9
≥530 & <1,050	5.4	6.5	5.8	7.5	6.3	8.4
≥1,050 & <1,580	5.8	6.8	6.2	8.1	6.5	8.8
≥1,580	6.3	7.0	6.5	8.9	6.7	9.1

### 5.1.1.6 Water Cooled Chilled Water Systems

Water-cooled chillers incorporate the use of cooling towers, which improve heat rejection more efficiently at the condenser than air-cooled chillers. For a water-cooled chiller, the cooling tower rejects heat to the environment through direct heat exchange between the condenser water and cooling air, however, the costs associated with water and water treatment need to be factored in.

Table 5-EMinimum Energy Efficiency Requirements for air cooled Chillers

	ECBC Building		ECBC+ Building		SuperECBC Building
	COP	IPLV	COP	IPLV	COP/ IPLV
Chiller Capacity (kW <sub>r</sub> )					
<260	2.8	3.5	3.0	4.0	NA
≥260	3.0	3.7	3.2	5.0	NA

## VRF System

### 5.1.1.7 Variable Refrigerant Flow Systems

In conventional systems the heat is transferred from the space to the refrigerant by circulating air (in ducted systems) or water (in chillers) throughout the building. The fundamental difference between ductless products from ducted systems is that heat is transferred to or from the space directly by circulating refrigerant to evaporators located near or within the conditioned space.

Variable Refrigerant Flow (VRF) systems are more complex, larger capacity versions of the ductless multi-split system, additionally capable of connecting ducted style fan coil units. They have multiple compressors, many evaporators, and complex oil and refrigerant management and control systems. They do not have built in ventilation, so an additional dedicated outdoor air system (DOAS) is required.

The VRF system can control the amount of refrigerant flowing to each of the evaporators, enabling the use of many evaporators of differing capacities and configurations, individualized comfort control, simultaneous heating and cooling in different zones, and heat recovery from one zone to another. This refrigerant flow control is the fundamental of VRF systems and is the major technical challenge as well as the source of many of the system's advantages.

**Modularity-** VRF systems are lightweight and modular, multiples of these modules can be used to achieve cooling capacities of

hundreds of tons. Each module is an independent refrigerant loop, controlled by a common control system.

Each module can be transported easily and fits into a standard elevator. The modularity also enables staged, floor-by-floor installations.

As the system is light weight, it also reduces requirements for structural reinforcement of roofs. Also, as the ductwork is required only for the ventilation system, it can be smaller than the ducting in standard ducted systems, reducing the floor to ceiling height.

There is also no need for a machine room, as, the condensing units are normally placed outdoors.

*Maintenance* -VRF, similar to that of any DX system, consists mainly of changing filters and cleaning coils.

*Thermal Comfort* – As VRF systems use variable speed compressors with wide capacity modulation capabilities, they can maintain precise temperature control, generally within  $\pm 1^{\circ}\text{F}$  ( $\pm 0.6^{\circ}\text{C}$ ), thus, each thermal zone (space) can have an individual setpoint control.

The energy efficiency of VRF systems is higher as the system eliminates duct losses, which are often estimated to be between 10% to 20% of total airflow in a ducted system. Also, VRF systems typically include two to three compressors, one of which is variable speed, in each condensing unit, enabling wide capacity modulation, thus, high part-load efficiency.

*Table 5-F Minimum Efficiency Requirements for VRF Air conditioners for ECBC Building\**

		For Heating or cooling or both	
Type	Size category (kW <sub>r</sub> )	EER	IEER
VRF Air Conditioners, Air cooled	< 40	3.28	4.36
	>= 40 and < 70	3.26	4.34
	>= 70	3.02	4.07

\* The revised EER and IEER values as per Indian Standard for VRF corresponding to values in this table will supersede as and when the revised standards are published.

## Low-Energy Comfort Systems

### 5.1.1.8 Evaporative Cooling

The process relies on the evaporation of water to produce significant cooling with extremely low energy consumption and no use of CFC's. It is also one of the simplest methods of cooling air and the principle of evaporative cooling remains a cost-effective method.

Two principle methods of evaporative cooling are:

#### **Direct Evaporative Cooling**

In this method, water evaporates directly into the airstream, thus reducing the air's dry-bulb temperature while humidifying the air.

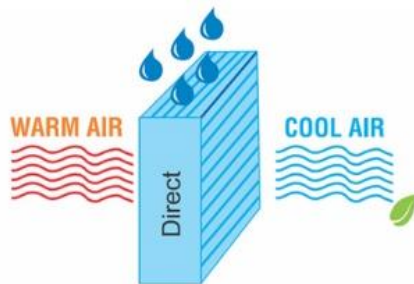

Figure 5- 1 Direct Evaporative Cooling System

The efficiency of direct cooling depends on the pad media. A good quality rigid cellulose pad can provide up to 90% efficiency while the loose aspen wood fiber pad shall result in 50% to 60% contact efficiencies.

#### **Indirect Evaporative Cooling**

This method lowers the temperature of air via some type of heat exchanger arrangement, in which a secondary airstream is cooled by water and which in turn cools the primary airstream. The cooled air never comes in direct contact with water. Both the dry bulb and wet bulb temperatures are reduced. This method cost more than direct coolers and operate at lower efficiency which is in the range of 60% - 70%.



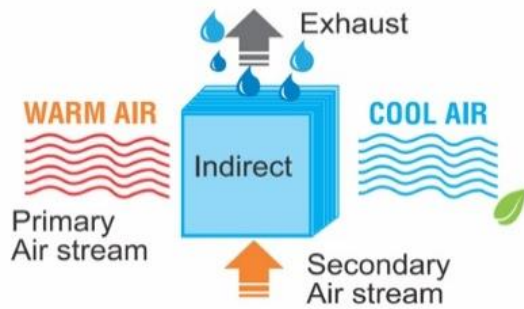

Figure 5- 2 Indirect Evaporative Cooling

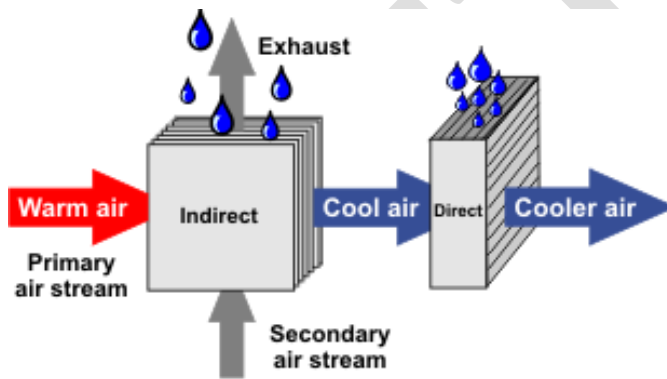

Figure 5- 3 Two-stage Evaporative Cooling

### **Two stage Indirect/direct Evaporative Cooling**

This strategy combines indirect with direct evaporative cooling. This is accomplished by passing air inside a heat exchanger that is cooled by evaporation on the outside. In the second stage, the pre-cooled air passes through a water soaked pad and picks up humidity as it cools.

As the air supply to the second stage evaporator is pre-cooled, less humidity is added to the air. The supply air is cooler than either a direct or indirect single stage system can provide individually. Variable speed drives can also be added to reduce further energy consumption.

The advantages of Evaporative cooling system are:

*Operational Cost*-Evaporative coolers do not use compressors, condenser, chiller coils, cooling towers or heavily insulated piping. Thus, the cost of acquisition and operation is a fraction of conventional air conditioning and mechanical refrigeration systems.

*Maintenance Cost* -Maintenance costs are minimal requiring simpler procedures and lower skilled maintenance people. It reduces radiated heat by constant flow of cool air which absorbs heat from all exposed surfaces and results in a reduction of the heat radiated to the human body. Unlike air conditioning, evaporative cooling does not require an airtight structure to operate at maximum efficiency and building occupants can open doors and windows. It is environmental friendly as it has no CFC's or HCFC's.

Hot & Dry climate zone is best suited for evaporative coolers as the mean maximum monthly temperature remains above 30°C and relative humidity around 55%.

They are not effective in the humid regions as the cooling capability gets decreased with increase of humidity levels in ambient air. Humid air supplied by evaporative cooler can accelerate corrosion of equipment kept in the concerned space.

These coolers use on-site water, hence adequate water availability should be required on-site. Compared to vapor compression systems, evaporative coolers require increased air flow rates to compensate for higher supply air temperatures. Air velocity when operating on high speed may cause annoying noise.

#### 5.1.1.9 Radiant Cooling/Heating System

A radiant system consists of a high-efficiency chilled-water system that distributes water to radiant cooling panels or to tubing imbedded in floor slabs in each thermal zone to provide local cooling.

The radiant system takes care of sensible heating and cooling. The dehumidification and humidification, and ventilation requirements must be provided by a DOAS.

*Energy Efficiency* – The large surface area of the systems enables heating and cooling loads to be met with very low-temperature hot water and relatively high-temperature chilled water.

Heating or cooling energy is transferred to the space entirely by natural convection and radiant means.

*Implementation*- The systems may be implemented using ceiling mounted radiant panels that affix water tubing to a ceiling tile. The tubing is served by water piping above the ceiling.

An alternate system, uses polymer tubing imbedded in concrete floor slabs.

*Thermal Comfort* -Valving controls water flow to sections of the ceiling to provide temperature control in the space. If the system is used for both heating and cooling, the ceiling may be divided into interior and perimeter zones with four pipes (hot and chilled water) to the perimeter zones.

A Well-designed radiant system uses the thermal capacitance of the floor slab to mitigate transient loads and provide consistent interior comfort conditions.

Radiant floors are less effective for space cooling. Radiant ceilings are used in office spaces, while radiant floors are seen in lobbies, atriums, and circulation spaces.

Avoidance of condensation on the cooling surfaces is the most important design consideration for radiant cooling systems, especially in humid climates.

Mechanisms for avoiding condensation include the following (ASHRAE AEDG, 2014):

- Control of entering dew-point temperature of ventilation air to meet maximum interior air dew-point temperature limits.
- Design of radiant cooling systems to meet sensible cooling loads with elevated (>60°F) chilled-water temperatures.
- Monitoring of space dew-point temperature with radiant system shutdown upon detection of elevated space dew-point temperature.

- Design of building envelope systems to minimize infiltration. Construction-phase quality control of envelope systems to meet infiltration specifications.
- Removal of radiant cooling elements from areas immediately surrounding exterior doors.
- Provision of excess dehumidified ventilation air adjacent to likely sources of exterior air infiltration.

#### 5.1.1.10 Ground Source Heat Pump

The Ground Source Heat Pump (GSHP) system takes advantage of the high thermal capacitance of the earth to store heat rejected into the ground during the cooling system as a resource for winter heating.

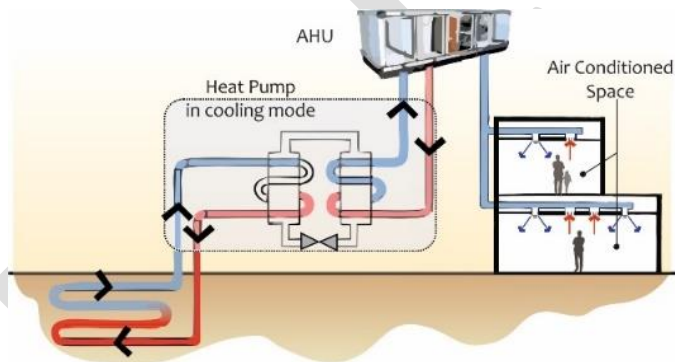

Figure 5- 4 Schematic Diagram of a Ground Source Heat Pump

*System Design and Sizing-* The successful implementation of a ground-coupled heat pump system requires a balance between the amount of heat extracted from the ground for the heating cycle and the amount of heat rejected into the ground for the cooling cycle.

An appropriately sized system will have a relatively lower heat rejection temperature during the summer compared with cooling tower heat rejection.

Following are some considerations for incorporation of a ground-coupled heat pump (ASHRAE AEDG, 2014):

- Balance of summer cooling loads with winter heating loads.
- Accurate determination of heat diffusivity of earth in contact with the ground-coupled heat transfer system

- Adequate sizing of the ground-coupling system, using accurate ground thermal diffusivity information, to limit maximum supply water temperature during the summer. And minimum supply water temperature during the winter
- Appropriate design and control of the hydronic circulation system to optimize pumping energy and maximization of heat pump annual heating and cooling efficiency.

### 5.1.2 HVAC Controls

To comply with the ECBC, the buildings shall have the following controls:

#### 5.1.2.1 Timeclock

As per the ECBC 2017, mechanical cooling and heating systems in Universities and Training Institutions of all sizes and all Shopping Complexes with built up area greater than 20,000 m<sup>2</sup> shall be controlled by timeclocks that:

- a) Can start and stop the system under different schedules for three different day-types per week,
- b) Are capable of retaining programming and time setting during loss of power for a period of at least 10 hours, and
- c) Include an accessible manual override that allows temporary operation of the system for up to 2 hours.

Exceptions

- a) Cooling systems less than 17.5 kW<sub>r</sub>
- b) Heating systems less than 5.0 kW<sub>r</sub>
- c) Unitary systems of all capacities

There are a number of methods of employing time schedules.

**Time switch:** Services are switched on or off in accordance with time settings.

**Seven-day programmer:** This is used for switching HVAC systems on, off, or to a setback mode at different times during the week according to the occupancy levels.

**Optimum time controls:** These switch the HVAC systems on just in time to reach the required temperature at the start of occupation.

### 5.1.2.2 Temperature Controls

As per the ECBC 2017, mechanical heating and cooling equipment in all buildings shall be installed with controls to manage the temperature inside the conditioned zones.

Each floor or a building block should have at least one control to manage the temperature.

These controls should meet the following requirements:

- a) Where a unit provides both heating and cooling, controls shall be capable of providing a temperature dead band of 3.0°C within which the supply of heating and cooling energy to the zone is shut off or reduced to a minimum.

*Deadband* - A deadband is an area of a signal range where no action occurs. It is to prevent repeated activation-deactivation cycles, often referred to as *hunting*. For example, in a typical office building the heating should switch off when a temperature of 18°C has been reached and cooling should not come on until the temperature exceeds 21°C. The 3°C gap between the setpoints prevents simultaneous heating and cooling occurring and is referred to as the deadband.

- a) Where separate heating and cooling equipment serve the same temperature zone, temperature controls shall be interlocked to prevent simultaneous heating and cooling.

A *software interlock* ensures that simultaneous heating and cooling does not occur within a HVAC system, as, heating and cooling elements of a system can conflict with each other in an effort to maintain a zone's temperature requirement.

- b) Separate thermostat control shall be installed in each
  - i. guest room of Resort and Star Hotel,
  - ii. room less than 30 m<sup>2</sup> in Business,
  - iii. air-conditioned class room, lecture room, and computer room of Educational,
  - iv. in-patient and out-patient room of Healthcare

The thermostat setpoints depend on a number of factors, including the process undertaken in an area, product quality requirements, occupancy levels, etc.

Control systems compare measured current temperature values with the desired setpoint value, and, apply the required actions to manipulate the measured value up or down as required by the setpoint.

Control systems have one or more sensors reporting to a control device. The systems control logic uses this information to determine if heating or cooling is required.

All the critical sensors responsible for the operation of an energy consuming HVAC element should be placed on an actively maintained calibration schedule to ensure that the values reported to a control device are accurate, for an efficient functioning of the system.

#### 5.1.2.3 Occupancy Controls

As per the ECBC 2017, Occupancy controls shall be installed to de-energize or to throttle to minimum the ventilation and/or air conditioning systems when there are no occupants in:

- (a) Each guest room in a Resort and Star Hotel
- (b) Each public toilet in a Star Hotel or Business with built up area more than 20,000 m<sup>2</sup>
- (c) Each conference and meeting room in a Star Hotel or Business
- (d) Each room of size more than 30 m<sup>2</sup> in Educational buildings

Occupancy control allows for the automatic switching of a ventilation system if the occupants in an area is detected. The most prevalent form of occupancy detection is passive infrared (PIR) sensors, suitable for areas that are occupied intermittently.

To optimise the energy consumption and indoor air quality according to the occupancy, the CO<sub>2</sub> levels are measured in the occupied zone and used as the control input. The speed of the ventilation fan is controlled to maintain the desired level of CO<sub>2</sub>.

This type of control is suitable for spaces with varying occupant density.

#### 5.1.2.4 Fan Controls

As per the ECBC 2017, cooling towers in buildings with built up area greater than 20,000 m<sup>2</sup>, shall have fan controls based on wet bulb logic, with either:

- a) Two speed motors, pony motors, or variable speed drives controlling the fans, or
- b) Controls capable of reducing the fan speed to at least two third of installed fan power

#### 5.1.2.5 Dampers

As per the ECBC 2017, all air supply and exhaust equipment, having a Variable Frequency Drive (VFD), shall have dampers that automatically close upon:

- (a) Fan shutdown, or,
- (b) When spaces served are not in use
- (c) Backdraft gravity damper is acceptable in the system with design outdoor air of the system is less than 150 liters per second in all climatic zones except cold climate, provided backdraft dampers for ventilation air intakes are protected from direct exposure to wind.
- (d) Dampers are not required in ventilation or exhaust systems serving naturally conditioned spaces.
- (e) Dampers are not required in exhaust systems serving kitchen exhaust hoods.

Modulating dampers on the fresh-air intake, exhaust air and return-air ductwork minimises the heating or cooling load of the unit, as it enables an AHU to control the mixing ratio of air in order to achieve the optimum condition of air exiting the mixing section.

Typically, a unit may have these dampers in a fixed position to achieve the minimum fresh-air requirement, as demanded by the energy service requirement. To achieve 'free' cooling, the ratio of fresh air and recirculating air allowed to enter the mixing section of the unit can be altered.

To meet the temperature setpoint, the first measure is to alter the quantity of fresh air. If the fresh-air percentage has been maximised the temperature setpoint is not achieved, the HVAC system should enter cooling mode and the cooling valve opened to allow mechanical cooling of the air.

For instance, if a space requires 16°C supply air, and, the return air from the space is at 21°C and the outside air is at 10°C. If the



fixed fresh-air intake is kept at a rate of 10%, the temperature of the supply air exiting the mixing section of the unit will be 19.9°C, indicating that there is a cooling requirement within the unit.

However, if the mixing ratio is modulated to 45% fresh-air intake, it will result in a supply air temperature of 16°C exiting the mixing section of the unit; hence the system is able to avail 'free' cooling in place of a costly mechanical cooling.

### **5.1.3 Additional Controls For ECBC+ and SuperECBC Buildings**

#### **5.1.3.1 Centralized Demand Shed Controls**

As per the ECBC 2017, ECBC+ and SuperECBC Buildings with built up area greater than 20,000 m<sup>2</sup> shall have a building management system. All the mechanical cooling and heating systems in ECBC+ and SuperECBC Buildings with any programmable logic controller (PLC) to the zone level shall have the following control capabilities to manage centralized demand shed in noncritical zones:

- (a) Automatic demand shed controls that can implement a centralized demand shed in non-critical zones during the demand response period on a demand response signal.
- (b) Controls that can remotely decrease or increase the operating temperature set points by four degrees or more in all noncritical zones on signal from a centralized control point
- (c) Controls that can provide an adjustable rate of change for the temperature setup and reset

The centralized demand shed controls shall have additional capabilities to

- (a) Be disabled by facility operators
- (b) Be manually controlled from a central point by facility operators to manage heating and cooling set points

Energy can continuously be monitored by BMS and the system can either sound the alarm or even take corrective action if certain parameters are exceeded. An example being the load shedding or load limiting where during certain times of maximum demand, the operation of equipment such as chillers and electrode humidifiers can be restricted.

### 5.1.3.2 Supply Air Temperature Reset

As per the ECBC 2017, multiple zone mechanical cooling and heating systems in ECBC+ and SuperECBC Buildings shall have controls that automatically reset the supply-air temperature in response to building loads or to outdoor air temperature.

Controls shall reset the supply air temperature to at least 25% of the difference between the design supply air temperature and the design room air temperature.

### 5.1.3.3 Chilled Water Temperature Reset

As per the ECBC 2017, Chilled water systems with a design capacity exceeding 350 kW<sub>r</sub> supplying chilled water to comfort conditioning systems in ECBC+ and SuperECBC Buildings shall have controls that automatically reset supply water temperatures by representative building loads (including return water temperature) or by outdoor air temperature.

Controls to automatically reset chilled water temperature shall not be required where the supply temperature reset controls causes improper operation of equipment.

## 5.1.4 Additional Controls For SuperECBC Buildings

### 5.1.4.1 Variable Air Volume Fan Control

VAV boxes or VAV terminals devices control the supply air flow into zones within occupied spaces.

As per the ECBC 2017, Fans in Variable Air Volume (VAV) systems in SuperECBC Buildings shall have controls or devices that will result in fan motor demand of no more than 30% of their design wattage at 50% of design airflow based on manufacturer's certified fan data.

A typical VAV box receives supply air from an AHU and a box serves a number of supply air diffusers located within a zone in the occupied space. During the HVAC design, parameters for a zone are sometimes changed and factors such as higher occupant densities, higher equipment loads, the installation of partitions and the location of office equipment in a manner that affects temperature sensors are not considered, leading to non-performance of VAV boxes and energy wastage.

The VAV box is controlled by a temperature sensor, the supply air volume being reduced as the zone temperature reaches set point, a minimum supply air rate being maintained for ventilation purposes.

Some of the issues that affect the efficiency and performance of a VAV box are:

- Setting up of design maximum and minimum air flows in VAV boxes poorly
- lack of coordination between VAV boxes and the AHU that serves them
- broken VAV boxes and leaking hot water valves
- Zone set points are altered by operators to 'quick fix' complaints of discomfort, without investigation of the root causes

### **5.1.5 System Balancing**

As per the ECBC 2017, system balancing shall be done for systems serving zones with a total conditioned area exceeding 500 m<sup>2</sup>.

#### **5.1.5.1 Air System Balancing**

Air systems shall be balanced in a manner to first minimize throttling losses; then, for fans with fan system power greater than 0.75 kW, fan speed shall be adjusted to meet design flow conditions.

#### **5.1.5.2 Hydronic System Balancing**

Hydronic systems shall be proportionately balanced in a manner to first minimize throttling losses; then the pump impeller shall be trimmed or pump speed shall be adjusted to meet design flow conditions.

### **5.1.6 Condensers**

Condensers shall be located such that the heat sink is free of interference from heat discharge by devices located in adjoining spaces, and do not interfere with other such systems installed nearby.

## 5.1.7 Service Hot Water Heating

### 5.1.7.1 Solar Water Heating

As per ECBC 2017, to comply with the Code, Hospitality and Healthcare projects in all climatic zones shall have equipment installed to provide at least 40% of the total hot water design capacity. Whereas, all the buildings in cold climate zone with a hot water system, shall have solar water heating equipment installed to provide at least 60% of the total hot water design capacity.

Exceptions : Systems that use heat recovery to provide the hot water capacity required as per the building type, size and efficiency level.

### 5.1.7.2 Heating Equipment Efficiency

Service water heating equipment shall meet or exceed the performance and minimum efficiency requirements presented in available Indian Standards

- (a) Solar water heater shall meet the performance/ minimum efficiency level mentioned in IS 13129 Part (1&2)
- (b) Gas Instantaneous water heaters shall meet the performance/minimum efficiency level mentioned in IS 15558 with above 80% Fuel utilization efficiency.
- (c) Electric water heater shall meet the performance/ minimum efficiency level mentioned in IS 2082.

### 5.1.7.3 Other Water Heating System

Supplementary heating system shall be designed to maximize the energy efficiency of the system and shall incorporate the following design features in cascade:

- (a) Maximum heat recovery from hot discharge system like condensers of air conditioning units,
- (b) Use of gas fired heaters wherever gas is available, and
- (c) Electric heater as last resort.

### 5.1.7.4 Piping Insulation

Piping insulation shall comply with § 0. The entire hot water system including the storage tanks, pipelines shall be insulated

conforming to the relevant IS standards on materials and applications.

#### 5.1.7.5 Heat Traps

Vertical pipe risers serving storage water heaters and storage tanks not having integral heat traps and serving a non-recirculating system shall have heat traps on both the inlet and outlet piping.

#### 5.1.7.6 Swimming Pools

All heated pools shall be provided with a vapor retardant pool cover on or at the water surface. Pools heated to more than 32°C shall have a pool cover with a minimum insulation value of R-4.1.

### 5.1.8 Economizers

Economizers contribute to energy savings by providing free cooling when ambient conditions are suitable to meet all or part of the cooling load.

A motorized outdoor air damper should be used to prevent unwanted outdoor air from entering during unoccupied period.

For all the climate zones, the motorized damper should be closed during the entire unoccupied period.

In warm and humid climates, enthalpy-based controls is recommended (versus dry-bulb temperature controls) to help ensure that unwanted moisture is not introduced into the space.

A dysfunctional economizer can cause substantial wastage of energy because of malfunctioning dampers or sensors and requires periodic maintenance.

ECBC 2017 recommends that each cooling fan system in buildings with built up area greater than 20,000 m<sup>2</sup>, shall include at least one of the following:

- (a) An air economizer capable of modulating outside-air and return-air dampers to supply 50% of the design supply air quantity as outside-air.
- (b) A water economizer capable of providing 50% of the expected system cooling load at outside air temperatures of 10°C dry-bulb/7.2°C wet-bulb and below.

Projects exempted include:

- (a) Projects in warm-humid climate zones
- (b) Projects with only daytime occupancy in the hot-dry are exempt.
- (c) Individual ceiling mounted fan systems is less than 3,200 liters per second exempt.

In addition, economizers shall be capable of providing partial cooling even when additional mechanical cooling is required to meet the cooling load.

Air economizer shall be equipped with controls

- (a) That allow dampers to be sequenced with the mechanical cooling equipment and not be controlled by only mixed air temperature.
- (b) capable of automatically reducing outdoor air intake to the design minimum outdoor air quantity when outdoor air intake will no longer reduce cooling energy usage.
- (c) Capable of high-limit shutoff at 24 °C dry bulb temperature.

### **5.1.9 Energy Recovery**

Energy recovery ventilation has three categories of application:

- (a) process-to-process,
- (b) process-to comfort, and
- (c) comfort-to-comfort.

In process-to-process applications, only the sensible heat is captured from the process exhaust stream and transferred to the process supply stream. Exhaust temperature may be as high as 800°C.

In the process-to-comfort applications, energy recovery , also, involves the capture and transfer of sensible heat only. Waste heat is transferred to makeup or outdoor air streams. Although, this is effective during winter months, it requires modulation during spring and autumn to prevent overheating of the building. Mostly, no energy recovery is made during summer months.

The Comfort-to-comfort applications differ from other categories as both sensible and latent heat are transferred. The energy recovery device transfers sensible heat from the warmer air stream to the cooler air stream. In addition, It also transfers

moisture from the air stream with the higher humidity ratio to the air stream with the lower humidity ratio. The directions of humidity and heat transfer may not necessarily be the same.

ECBC 2017 mandates that all Hospitality and Healthcare, with systems of capacity greater than 2,100 liters per second and minimum outdoor air supply of 70% shall have air-to-air heat recovery equipment with minimum 50% recovery effectiveness

In addition, at least 50% of heat shall be recovered from diesel and gas fired generator sets installed in Hospitality, Healthcare, and Business buildings with built up area greater than 20,000 m<sup>2</sup>.

DRAFT

## 5.2 Lighting and Controls

### 5.2.1.1 Reduced Interior Lighting Power Density

The primary lighting goals for commercial lighting are to optimize the regularly used spaces for daylight integration and to provide appropriate lighting levels in the occasionally used spaces.

To achieve maximum lighting energy savings, lighting power densities (LPDs) need to be reduced

Each building space distribution will be different, which offers different opportunities for energy savings.

The ECBC recommends the following methods for interior lighting power allowance calculations:

- **Building Area Method**

Determine the allowed lighting power density for each appropriate building area type from Table F- 1 for ECBC Buildings, from Table F- 2 for ECBC+ Buildings and from **Error! Reference source not found.** Table F- 1 for SuperECBC Buildings.(Appendix F)

- a) Calculate the gross lighted carpet area for each building area type.
- b) The interior lighting power allowance is the sum of the products of the gross lighted floor area of each building area times the allowed lighting power density for that building area type.

- **Space Function Method**

Determination of interior lighting power allowance (watts) by the space function method shall be in accordance with the following:

- a) Determine the appropriate building type and the allowed lighting power density from Table F-4 for ECBC Buildings Table F- 5 for ECBC+ Buildings and, Table F-6 for SuperECBC Buildings. In cases where both a common space type and building specific space type are listed, building specific space type LPD shall apply.



- b) For each space, enclosed by partitions 80% or greater than ceiling height, determine the gross carpet area by measuring to the face of the partition wall. Include the area of balconies or other projections. Retail spaces do not have to comply with the 80% partition height requirements.
- c) The interior lighting power allowance is the sum of the lighting power allowances for all spaces. The lighting power allowance for a space is the product of the gross lighted carpet area of the space times the allowed lighting power density for that space.

#### 5.2.1.2 Sensors and Controls

The lighting controls i.e. Automatic Lighting shut-off, Space Control, Control in Daylight Areas and exterior lighting controls is a mandatory clause for ECBC compliance. In addition, centralized controls are required for ECBC+ and SuperECBC Buildings.

##### *Automatic Lighting Shut-off*

In a building or space of building larger than 300 m<sup>2</sup>, 90% of interior lighting fittings shall be equipped with automatic control device.

Additionally, occupancy sensors shall be provided in all building types greater than 20,000 m<sup>2</sup> Built up area (BUA), in

- All habitable spaces less than 30 m<sup>2</sup>, enclosed by walls or ceiling height partitions.
  - All storage or utility spaces more than 15 m<sup>2</sup>
  - Public toilets more than 25 m<sup>2</sup>, controlling at least 80 % of lighting fitted in the toilet. The lighting fixtures, not controlled by automatic lighting shutoff, shall be uniformly spread in the area.
- i. Corridors of all Hospitality greater than 20,000 m<sup>2</sup> BUA, controlling minimum 70% and maximum 80% of lighting by wattage, fitted in the public corridor. The lighting fixtures, not controlled by automatic lighting shut off, shall be uniformly spread in the area.
  - ii. All conference or meeting rooms.

Automatic control device shall function on either:

- i. A scheduled basis at specific programmed times. An independent program schedule shall be provided for areas of no more than 2,500 m<sup>2</sup> and not more than one floor, or,
- ii. Occupancy sensors that shall turn off the lighting fixtures within 15 minutes of an occupant leaving the space. Light fixtures controlled by occupancy sensors shall have a wall-mounted, manual switch capable of turning off lights when the space is occupied.

Lighting systems designed for emergency and firefighting purposes are exempted.

#### 5.2.1.3 Space Control

All spaces enclosed by ceiling-height partitions shall have at least one control device to independently control the general lighting within the space.

The control device can be activated either manually by an occupant or automatically by sensing an occupant. Each control device shall

- (a) control a maximum of 250 m<sup>2</sup> for a space less than or equal to 1,000 m<sup>2</sup>, and a maximum of 1,000 m<sup>2</sup> for a space greater than 1,000 m<sup>2</sup>.
- (b) have the capability to override the shutoff control required in § 5.2.1.3 for no more than 2 hours, and
- (c) be readily accessible and located so the occupants can see the control.

#### 5.2.1.4 Control in Daylight Areas

- a) Luminaires, installed within day lighting areas shall be equipped with either a manual control device to shut off luminaires, installed within day lit area, during potential daylight time of a day or automatic control device that:
  - i. Has a delay of minimum 5 minutes, or,
  - ii. Can dim or step down to 50% of total power.
- b) Overrides to the daylight controls shall not be allowed.
- c) ECBC+ and SuperECBC building shall have centralized control system for schedule based automatic lighting shutoff switches

#### 5.2.1.5 Exterior Lighting Control

For all ECBC, ECBC+ and SuperECBC buildings, exterior lights shall have lamp efficacy not less than 80 lumens per watt, 90 lumens per watt, and 100 lumens per watt, unless the luminaire is controlled by a motion sensor or exempted.

DRAFT

## 5.3 Electrical and Renewable Energy Systems

### 5.3.1 Transformer

Transformer is a static device which transforms energy from one electrical circuit to another circuit with the help of mutual induction between primary and secondary windings.

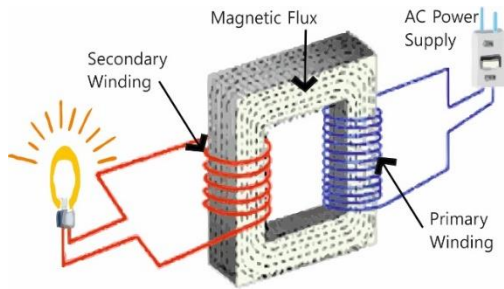

*Figure 5- 5 Schematic diagram of a transformer*

These windings are wound around different cores or single core. Windings have different number of turns with respect to each other. The purpose of transformer is to increase or decrease the level of voltage at the end of both the windings. According to this, transformers are classified as-

- Step up transformer
- Step down transformer

Step up transformer raises the output voltage, whereas step down transformer reduces output voltage. Based on the application, transformers are categorized as power transformer and distribution transformer.

## Power Transformer

Power transformers are used in transmission network of higher voltages, deployed for step-up and step-down transformer application (400 kV, 200 kV, 110 kV, 66 kV, 33kV).

## Distribution Transformer

Distribution transformers are used to lower down the voltage in distribution networks for end user application (11kV, 6.6 kV, 3.3 kV, 440V, 230V).

Distribution transformers are further classified into different categories based on certain factors such as Type of thermal insulation, number of phases, mounting location, voltage class etc.

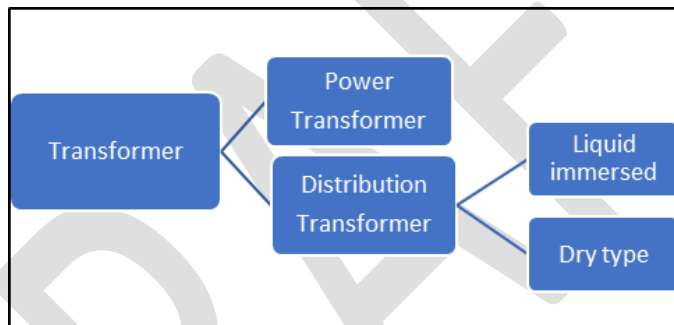

Figure 5- 6 Types of Transformers

On basis of thermal insulation, distribution transformer can be divided into two types-

- Liquid-immersed transformer
- Dry type transformer

In liquid immersed transformer, mostly oil is used for insulation as well as coolant purpose to dissipate heat generated in core of the transformer.

In dry type transformer windings with core are kept within a sealed tank that is pressurized with air.

### 5.3.1.1 Thermal insulation class in transformer-

When transformers operate, they tend to generate lot of heat due to the losses occurring during operation. So, it is not operated beyond defined impermissible temperature limit by

the manufacturer. Permissible limit of insulating materials are described by thermal insulation class.

#### INSULATION CLASS

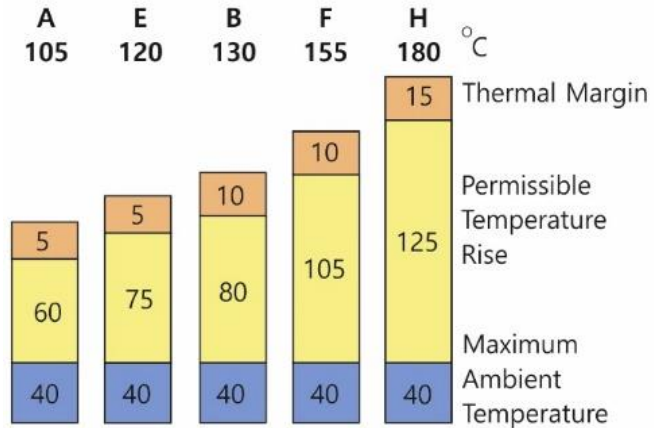

Figure 5- 7 Thermal insulation class (Source- NEMA service factor)

#### 5.3.1.2 Losses in transformer-

The efficiency varies anywhere between 96 to 99 percent. The efficiency of the transformers not only depends on the design, but also, on the effective operating load. Transformer losses consist of two parts: No-load loss and Load loss

##### No-load loss (core loss)

It occurs whenever the transformer is energized; core loss does not vary with load. Core losses are caused by two factors: hysteresis and eddy current losses. Hysteresis loss is that energy lost by reversing the magnetic field in the core as the magnetizing AC rises and falls and reverses direction. Eddy current loss is a result of induced currents circulating in the core. No load losses are generally provided by manufacturer.

### Load loss (also called copper loss)

It is associated with full-load current flow in the transformer windings. Copper loss is power lost in the primary and secondary windings of a transformer due to the ohmic resistance of the windings. Copper loss varies with the square of the load current and can be calculated by

$$P = I^2R$$

By considering both the losses, total transformer losses can be computed with the help of following formula:

$$P_{TOTAL} = P_{NO-LOAD} + \left(\% \frac{LOAD}{100}\right)^2 \times P_{LOAD}$$

$$\%LOAD = \left(\frac{kVA. LOAD}{RATED\ kVA}\right)$$

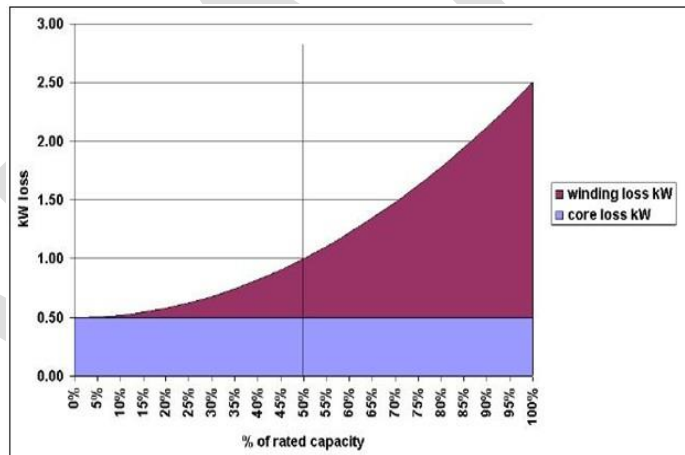

Figure 5- 8 Losses in Transformer (Source- BEE Book 3 Energy efficiency in electrical utilities)

### 5.3.1.3 Energy efficient transformers-

Major energy loss in dry type transformer occurs due to heat generated in the core. The iron loss of any transformer depends on its core. To reduce these losses electrical distribution transformers are made of amorphous metal core which provide excellent opportunity to conserve energy right from installation.



*Figure 5- 9 Amorphous core transformer*

Amorphous material has unique physical and magnetic property that helps in reducing core loss of transformers. Efficiency of amorphous core transformer could reach up to 98.5% at 35% load. These transformers are costlier than conventional (Si Fe core) transformers.



*Figure 5- 10 Conventional Transformer*

Conventional transformers are simple in construction but incurred core losses are around 70% more than amorphous core transformers.



#### 5.3.1.4 Location of transformer

In distribution system, major losses occur due to long distance between source (transformer) and load. The losses in current carrying wires depend on length of wire and its cross-sectional area. To minimize these types of losses in distribution network, transformer is placed near to the loads.

#### 5.3.2 Motors

Motors convert electrical energy into mechanical energy by the interaction between the magnetic fields set up in the stator and rotor windings. Industrial electric motors can be broadly classified as induction motors and direct current motors. All motor types have the same four operating components: stator, rotor, bearings and frame.

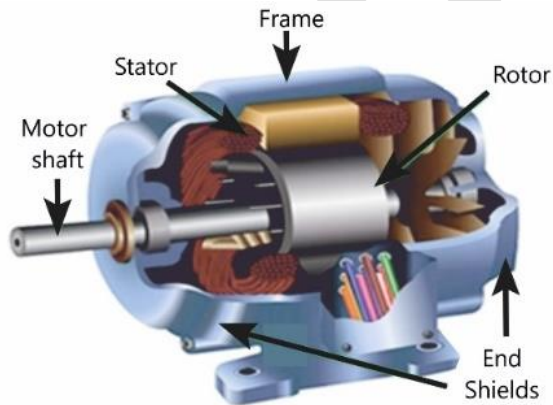

Figure 5- 11 Standard Motor Components

### 5.3.2.1 Types of motors

The primary classification of motors is tabulated as below:

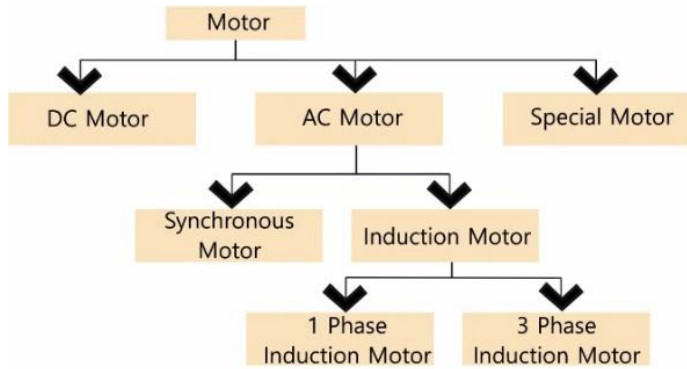

Figure 5- 12 Types of Motors

### 5.3.2.2 Induction motor

Induction motors are the most commonly used electrical machines. They are also known as asynchronous motors. Induction motors are cheaper, more rugged and easier to maintain compared to other alternatives.



Figure 5- 13 Induction motor

Another classification for induction motor is based on type of rotor as mentioned below:

- Squirrel cage motor
- Slip ring or wound rotor motor.

The main characteristic of induction motor is that the rotor will never be able to catch up with the speed of the magnetic field. It

rotates at a specific speed which is slightly less than synchronous speed. The difference in synchronous and rotor speed is known as slip. Synchronous speed can be calculated by the formula:

$$N_s = \left( \frac{120 \times f}{P} \right)$$

Where,

f= frequency in hertz

P= no. pf poles

### 5.3.2.3 Losses in induction motors

There are numerous energy losses associated with the motor. Various components of these losses are friction loss, copper loss, eddy current and hysteresis loss. Energy losses are dissipated as heat during the operation of motor.

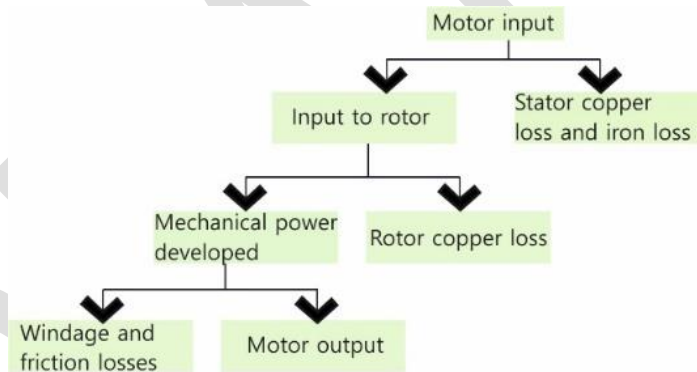

Figure 5- 14 Power loss in induction motor

Electric motors consume a significant amount of electricity in the industrial and in the tertiary sector of the India.

As induction motors are simple and robust, they are prime mover of the modern industry. The electric manufactures are seeking methods for improving the motor efficiencies, which resulted in a new generation of electric motors known as energy efficient motors. This transition is necessary due to limited energy sources and escalating energy prices.

### 5.3.2.4 Energy Efficient Motors (EEM)

It is simply a motor that gives same output strength by consuming lesser amounts of power. Energy-efficient motors possess better performance characteristics than their standard counterparts. High service factor, longer insulation, finer quality of material as well as low heat output, less vibration and lower incurred losses ensure the operational reliability of energy efficient motors. The efficiency levels defined in IEC 60034-30 are based on test methods specified in IEC 60034-2-1: 2007.

However, sophisticated construction makes energy efficient motors to be costlier than standard motors. EEM competes on efficiency and not on prices with respect to standard motors.

### 5.3.3 Efficiency standards in motors-

The International Electrotechnical Commission (IEC) international standards organization that prepares and publishes International Standards for all electrical equipment. IS (Indian Standard) uses same standards to classify the motor efficiency.

The classification is mentioned as below:

- IE1- Standard efficiency
- IE2- High efficiency
- IE3- Premium Efficiency
- IE4- Super-Premium Efficiency

Motor output ranges from 0.12kW-1000kW are classified under this standard

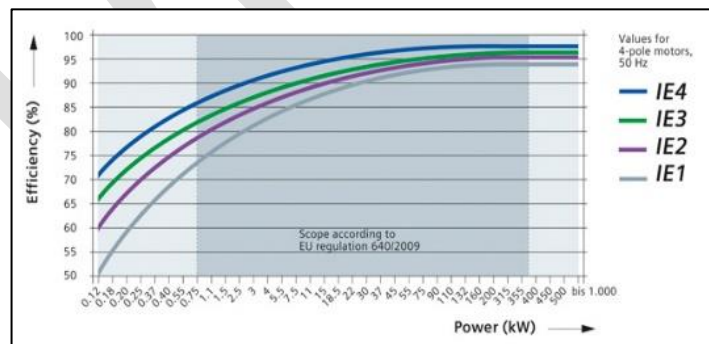

Figure 5- 15 IE class (Source: Siemens)

The IE standard defines efficiency classes for motors and harmonizes the currently different requirements for induction motor efficiency levels around the world. It will put an end to the difficulties encountered by manufacturers and suppliers of induction motors. producing motors for the global market. Motor users will benefit through the availability of more transparent and easier to understand information.

#### 5.3.3.1 Ways to improve Motor performance-

**Power quality-** Voltage unbalance, different sizes of cables in distribution network, frequency variation are some parameters which are held accountable for poor power quality. In order to carry out smooth functioning of motors all these factors are taken into consideration during motor installation as well as operation

**Power factor correction-** The impacts of PF correction include reduced kVA demand reduced I<sup>2</sup>R losses in distribution network reduced voltage drop in the cables and an increase in the overall efficiency of the plant electrical system. Capacitors connected in parallel (shunted) with the motor are typically used to improve the power factor. However, capacitors do not improve the operating power factor of motors. They help in increasing the power factor from motor terminal to utility supply.

**Maintenance-**Inadequate maintenance of motors can significantly increase losses and lead to unreliable operation. For example, improper lubrication can cause increased friction in both the motor and associated drive transmission equipment. Resistance losses in the motor, which rise with temperature, would increase. Providing adequate ventilation and keeping motor cooling ducts clean can help dissipate heat to reduce excessive losses. The life of the insulation in the motor would also be longer.

**Age-** Motors are not operated at ideal conditions throughout their life. So the various motor components such as rotor and stator conductor, cooling fan, couplings, insulation etc. which depend on the age of motor, inclusively degrade the actual performance of motor.

### 5.3.4 Diesel generator

Diesel generators are diesel fuel based prime mover which convert mechanical energy to electrical energy. DG set can be classified according to cycle type as:

- two stroke and
- four stroke.

However, the bulk of Internal combustion engines use the four stroke cycle.

The stages in four stroke diesel engine are: induction stroke, compression stroke, ignition & power stroke and exhaust stroke.

**1st: Induction stroke** - while the inlet valve is open, the descending piston draws in fresh air.

**2nd: Compression stroke** - while the valves are closed, the air is compressed to a pressure of up to 25 bar.

**3rd: Ignition and power stroke** - fuel is injected, while the valves are closed (fuel injection starts at the end of the previous stroke), the fuel ignites spontaneously and the piston is forced downwards by the combustion gases.

**4th: Exhaust stroke** - the exhaust valve is open and the rising piston discharges the spent gases from the cylinder.

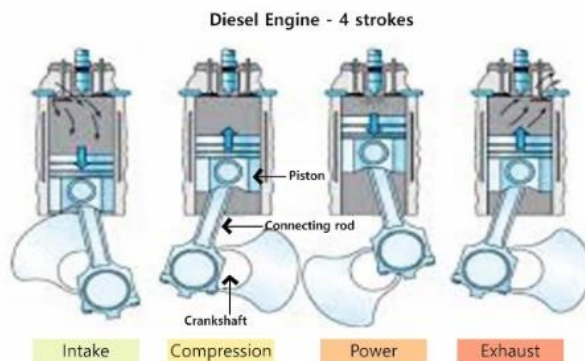

Figure 5- 16 Diesel Engine strokes

The shaft power developed by diesel engine is transmitted to alternator which converts it into electrical energy.

A diesel generating set is comprised of following components-

- The diesel engine and its accessories
- The AC Generator
- The control systems and switchgear
- The foundation and power house civil works
- The connected load with its own components like heating, motor drives, lighting etc.



*Figure 5- 17 Diesel Generator*

#### 5.3.4.1 DG set selection criteria

Two most important criteria power and speed need to be considered while selecting DG set.

The power requirement is determined by the maximum load. The engine power rating should be 10 – 20 % more than the power demand by the end use as it supplies power at the time overloading of machine.

To determine the speed requirement of an engine, one must again look at the requirement of the load. There will be an optimum speed at which fuel efficiency will be greatest. Engines should run as closely as possible to their rated speed to avoid poor efficiency and to prevent buildup of engine deposits due to incomplete combustion - which will lead to higher maintenance and running costs.

Along with power and speed other factors such as cooling mechanism, environment (temperature and humidity, dust, dirt etc.), control system, VSD etc. are also taken into consideration.

#### 5.3.4.2 BEE star rating of DG set

Bureau of energy efficiency facilitates performance rating for various equipment. For DG set, BEE specifies the star labelling for various classifications for the application, rating and performance of single/three phase Diesel Generating sets consisting of a Reciprocating Internal Combustion (RIC) engine driven by diesel as fuel, alternating current generator, any associated control gear, switchgear and auxiliary equipment. It applies to alternating current generating sets driven by RIC engines for land and marine use being manufactured, imported or sold in India.

Star rating or star level means the grade of energy efficiency based on specific fuel consumption (SFC) in g/kWh (electrical unit), displayed on the label of the generating set. The available stars are between a minimum of one and a maximum of five shown in table.

*Table 5-G BEE Star rating of DG sets*

<i>Star level</i>	<i>Specific Fuel Consumption (SFC) in g/kWh</i>
1	>302 & ≤336
2	>272 & ≤302
3	>245 & ≤272
4	>220 & ≤245
5	≤220

#### 5.3.4.3 Performance monitoring of DG set

Energy accountability is necessary for DG set in order to monitor the actual performance of DG sets. DG panel displays various parameters such as fuel consumption, kWh generated, KVA, PF, voltage, current, harmonic level etc. which are accounted for measurement and verification of DG operation.



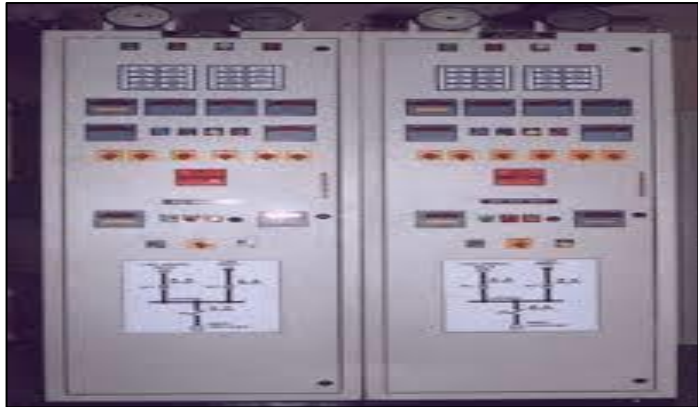

*Figure 5- 18 DG set panel*

The above figure depicts the electrical panel of DG set in which all DG parameter are digitally displayed and recorded.

#### 5.3.4.4 Energy saving measures in DG set

To achieve the maximum efficiency of DG set, following energy saving measures are taken into consideration:

- Steady load conditions on the DG set
- Quality of fuel and air intake
- Frequent calibration of fuel injection pumps
- Improve air filtration
- Selection of waste heat recovery system for steam generation or absorption chiller
- Parallel operation among the DG sets for improved loading and fuel economy.
- Adequate maintenance of DG and its auxiliaries
- Field trials to monitor DG set performance, and maintenance planning as per requirements.

#### 5.3.5 Uninterruptible Power Supply (UPS)

UPS provides backup power when utility power fails, either long enough for critical equipment to shut down gracefully so that no data is lost, or long enough to keep required loads operational until a generator comes online. Along with backup power it conditions incoming power so that quality power reaches to the load.

It dedicatedly serves the critical loads such as computers, servers, routers and other IT loads. As these kinds of loads require uninterrupted power supply, most of the critical loads are served by UPS which operate automatically upon disconnection of electricity.

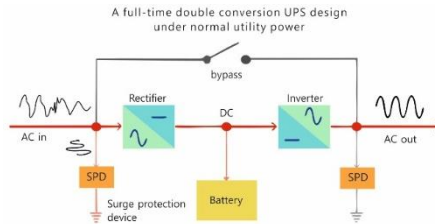

Figure 5- 19 UPS flow diagram

In above diagram, UPS converts input alternating current to direct current through a rectifier (AC to DC), and converts it back with an inverter (DC to AC). Batteries store energy to use in electricity failure. A bypass circuit routes power around the rectifier and inverter, running the critical load on incoming utility or generator power.

#### 5.3.5.1 Types of UPS

Classification of UPS is based on its application which is as follows:

- **Standby UPS-** The inverter only starts when the power fails, hence its name is given as standby UPS. High efficiency, small size, and low cost are the main benefits of this design. it is the most common type used for personal computers.
- **Line interactive UPS-** The Line Interactive UPS performs regulation operation in order to boost or lower down the voltage. Moreover, Its response time is substantially lesser than standby UPS system. This type of UPS system is commonly used for small business, Web, and departmental servers.
- **Standby-Ferro-** In the standby-ferro design, the inverter is in the standby mode, and is energized when the input power fails and the transfer switch is opened. Besides its high reliability and excellent filtering characteristic, lower efficiency as well as instability in operation makes it unsuitable. The Standby-Ferro UPS was once the dominant form of UPS in the 3-15kVA range.

- **Double conversion on-line-** In the double conversion on-line design, failure of the input AC does not cause activation of the transfer switch, because the input AC is charging the backup battery source which provides power to the output inverter. This is the most common type UPS above 10kVA.
- **Delta conversion on-line-** In the delta conversion on-line design, the delta converter acts with dual purposes. The first is to control the input power characteristics. Though it is similar to double conversion UPS system, the delta conversion on-line eliminates the drawbacks of the Double Conversion On-Line design. This type of UPS system is available in the range of 5kVA to 1 MW.

	Practical power range(kVA)	Voltage conditioning	Cost per VA	Efficiency	Inverter always operating
Standby	0-0.5	Low	Low	Very High	No
Line interactive	0.5-5	Design Dependent	Medium	Very High	Design Dependent
Standby-ferro	3-15	High	High	Low-Medium	No
Double conversion on-line	5-5000	High	Medium	Low-Medium	Yes
Delta conversion on-line	5-5000	High	Medium	High	Yes

Figure 5- 20 Characteristics of a UPS

Above table is a description of various parameters such as power range, voltage conditioning, efficiency for each type of UPS system.

### 5.3.5.2 Efficiency in UPS system

There are some losses incurred by the UPS circuit that causes lesser power available at user end than supply end. These losses occur due to internal circuitry of the UPS system. Generally, UPS has efficiency equal or greater than 90%. For some UPSs, it could reach up to 97%.

The Efficiencies of UPS system provided by manufacturer/supplier are often the values measured at the full rated load (100% FLR) of the UPS. Although it varies with

operating load. following figure shows the efficiency variation trend of UPS system.

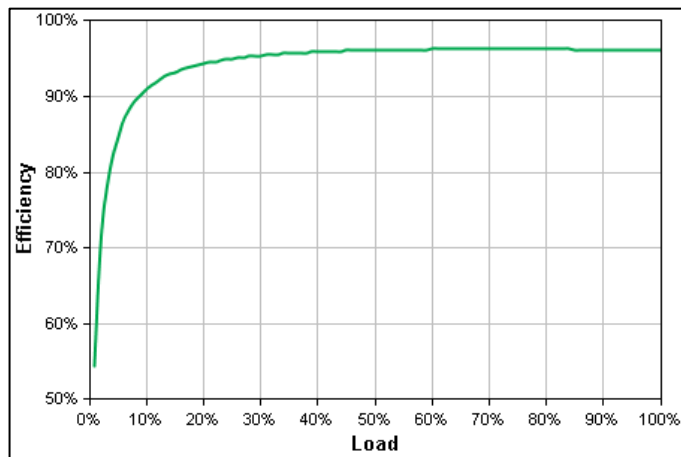

Figure 5- 21 UPS efficiency vs load (Source-Altruent Systems)

UPS efficiency is expressed as the ratio between the active output power and the active input power, without any transfer of energy to or from the battery (i.e. battery fully charged). The measurement must be made with appropriate instruments, in particular for non-linear loads. Standard EN62040-3 (part 6.3) defines the equipment that should be used.

### 5.3.6 Renewable Energy Systems

Renewable energy systems reduce the dependency on conventional sources of energy. Despite of high initial investment, renewable energy sources are being exploited and finding smooth way in near future. Renewable energy systems can be powered by-

- Solar energy
- Wind energy
- Biomass
- Geothermal energy
- Hydel energy etc.

On the basis of application, all the above sources have their own advantages and limitations also. e.g. Biomass based power generating units can use bagasse which is abundant in sugar mills but cannot be run in biomass/bagasse deficit areas. Moreover, there are various factors such as climate, cost, land

availability, public awareness etc. which affect the power generation from renewable sources.

### 5.3.6.1 Solar energy

Solar energy systems such as solar PV, solar water heater, solar cooker etc. are powered by sun radiation. Solar irradiation is converted into various forms of energy by incorporating the suitable technology.

Solar is emerging as a reliable source of energy at small as well as large scale. From KW to MW capacity solar PV plants are being installed to fulfil industrial as well as residential demand.

### 5.3.6.2 PV solar energy systems

Photovoltaic (PV) materials and devices convert sunlight into electrical energy. A single PV device is known as a cell. It is a elementary part of system which stands as an interface between sun radiation and end use application. An individual PV cell is usually small, typically producing about 1 or 2 watts of power. To boost the power output of PV cells, they are connected in chains to form larger units known as modules or panels. Modules can be used individually, or several can be connected to form arrays. One or more arrays is then connected to the electrical grid as part of a complete PV system. Because of this modular structure, PV systems can be built to meet almost any electric power need, small or large.

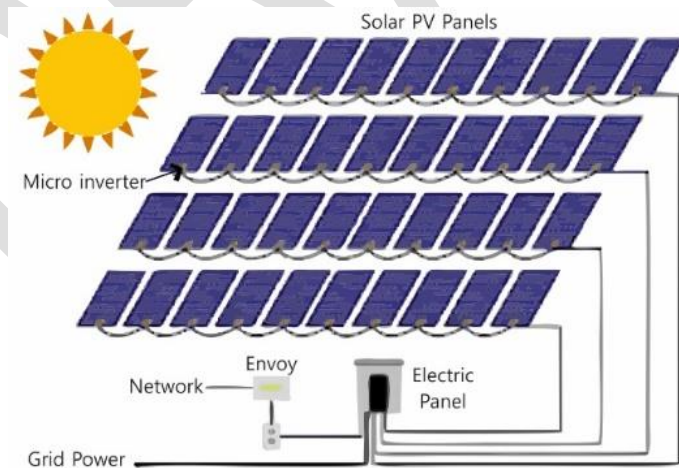

Figure 5- 22 Solar PV system

PV system also includes mounting structures that point panels toward the sun, along with the components that take the direct-current (DC) electricity produced by modules and convert it to the alternating-current (AC) electricity used to power all of the appliances.

### 5.3.6.3 Roof top solar PV-

A rooftop photovoltaic power station, or rooftop PV system, is a photovoltaic system that has panel mounted on the rooftop of a building. The various components of such a system include photovoltaic modules, mounting systems, cables, solar inverters and other electrical accessories. Roof top solar plants significantly contribute in powering residential as well as commercial building loads.

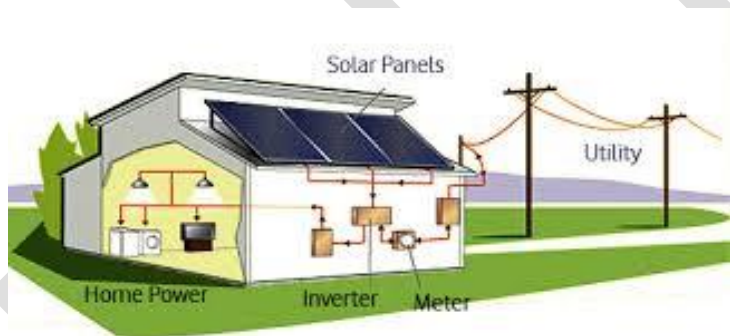

Figure 5- 23 Roof top solar

There has been a huge technological adoption in this field to overcome barriers at small scale application.

Mainly two distinct approaches are adopted to integrate solar in buildings-

- **On-grid solar-** These systems are designed to operate in connection with utility power grid. Such system can consume generated power inhouse or can inject excess power generated into the grid. Later on, injected units into the grid can be adjusted in the utility bills through net metering concept.

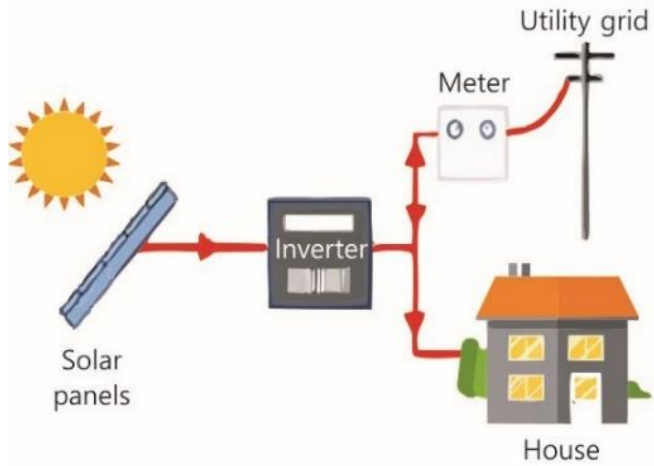

Figure 5- 24 On-grid Solar

- Off-grid/Hybrid solar-** It is decentralized mode of power generation. These systems are not connected to the grid and are designed operate in context of dedicated building or house. Produced electricity can be used by the building/house and batteries can be used to store excess electricity generated.

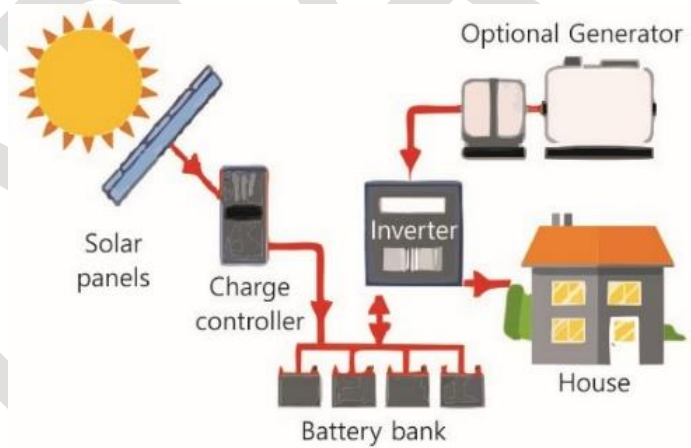

Figure 5- 25 Off-grid Solar

### 5.3.7 Power Factor

In major electrical applications, the loads are resistive and inductive. Resistive loads are incandescent lights and resistance heating. In pure resistive loads, power is expressed as active power in kW which is given by

$$P = V \times I$$

Where,

V=voltage and

I=current

In inductive loads such as motors, air conditioners, ballast type lighting, induction cookers etc. draw both active power to produce desired outcome and reactive power to establish electromagnetic fields. The reactive power is expressed in kVAr.

The vector sum of active and reactive power constitutes the total or apparent power drawn from utility or generating unit. It is expressed in kVA.

In inductive loads, current lags the voltage so the phase difference( $\phi$ ) between voltage and current would exist. The cosine of this phase difference( $\cos\phi$ ) is termed as power factor which is the ratio of active power(kW) to apparent power(kVA) and the values lies between 0 to 1.

Formula for power factor is given as

$$\text{Power Factor} = \cos \phi$$

kW/kVA where,  $\phi$  is phase angle

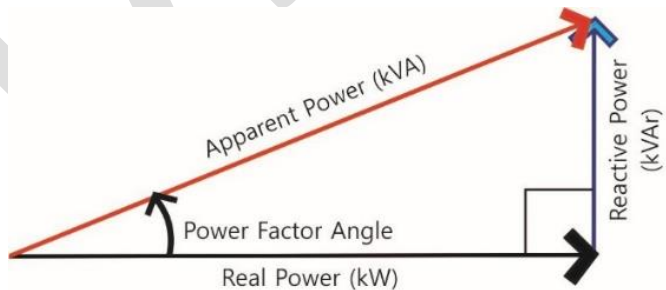

Figure 5- 26 Power components



### 5.3.7.1 Power factor calculation

In power factor calculation, we measure the source voltage and current drawn using a voltmeter and ammeter respectively. A wattmeter is used to record the active power.

Now, we know

$$P = V \times I \times \cos \varphi$$

From this,

$$\cos \varphi = \left( \frac{P}{V \times I} \right)$$

OR

$$\cos \varphi = \left( \frac{\text{Wattmeter reading}}{\text{Voltmeter reading} \times \text{Ammeter reading}} \right)$$

Hence, we can get the power factor.

Further, we can calculate the reactive power

$$Q = V \times I \times \sin \varphi$$

This reactive power can now be supplied from the capacitor installed in parallel with the concerned load in . Value of capacitor is calculated as per following formula:

$$Q = \frac{V^2}{X_c} = C = \frac{Q}{2\pi f V^2} \text{ farad}$$

### 5.3.7.2 Power factor correction

Power factor correction is basically an energy saving approach which reduces the overall power drawn from utility. power factor correction enables the service facility to improve the usage of power.

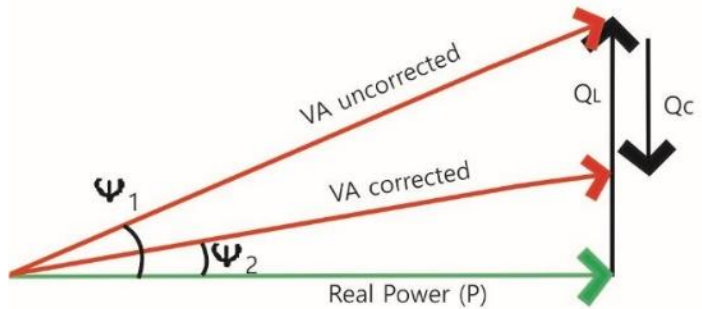

Figure 5- 27 Power factor correction

Real power is given by

$$P = V \times I \times \cos \phi$$

To transfer a given amount of power at certain voltage, the electrical current is inversely proportional to  $\cos \phi$ . Hence lower the pf higher will be the current flowing.

A large current flow requires more cross-sectional area of conductor and thus it increases material cost.

Poor power factor increases the current flowing in conductor and thus copper loss increases. Further large voltage drop occurs in alternator, electrical transformer and transmission and distribution lines.

Further the KVA rating of machines is also reduced by having higher power factor

$$KVA = \left( \frac{kW}{\cos \phi} \right)$$

### 5.3.7.3 Power factor improvement methods-

- **Capacitors**

Improving power factor means reducing the phase difference between voltage and current. Since majority of loads are of

inductive nature, they require some amount of reactive power for them to function. This reactive power is provided by the capacitor or bank of capacitors installed parallel to the load. They act as a source of local reactive power and thus less reactive power flows through the line. Basically, they reduce the phase difference between the voltage and current.



*Figure 5- 28 Capacitor bank*

- **Synchronous condenser**

They are 3 phase synchronous motor with no load attached to its shaft. The synchronous motor has the characteristics of operating under any power factor leading, lagging or unity depending upon the excitation. For inductive loads, synchronous condenser is connected towards load side and is overexcited. This makes it behave like a capacitor. It draws the lagging current from the supply or supplies the reactive power.



*Figure 5- 29 Synchronous condenser*

- **Phase Advancer**

This is an AC exciter mainly used to improve pf of induction motor. They are mounted on shaft of the motor and is connected in the rotor circuit of the motor. It improves the power factor by providing the exciting ampere turns to produce required flux at slip frequency. Further if ampere turns are increased, it can be made to operate at leading power factor.

DRAFT

DRAFT

# Chapter 6. DESIGN GUIDELINES MATRIX

## INTENT

The Design Guideline Matrix is a design tool with climate specific design strategies. The chapter contains prescriptive packages for energy savings that can be used to achieve the ECBC, ECBC + and Super ECBC code compliance

## SECTION ORGANIZATION



## 6.1 Climatic Zones of India

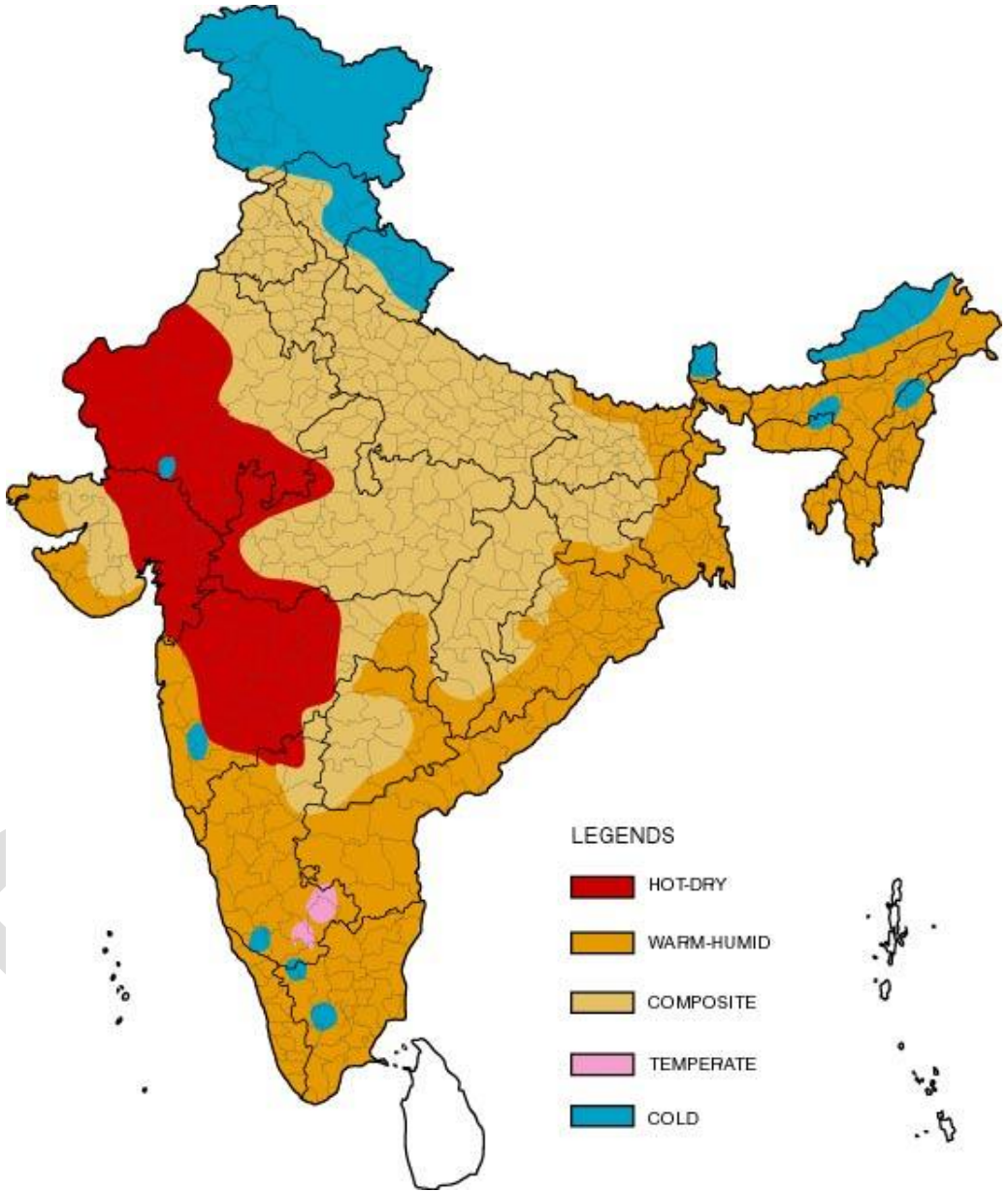

Table 6- A Climate Zone for Major Indian Cities

DRAFT



City	Climate Type	City	Climate Type
Ahmedabad	Hot & Dry	Kurnool	Warm & Humid
Allahabad	Composite	Leh	Cold
Amritsar	Composite	Lucknow	Composite
Aurangabad	Hot & Dry	Ludhiana	Composite
Bangalore	Temperate	Chennai	Warm & Humid
Barmer	Hot & Dry	Manali	Cold
Belgaum	Warm & Humid	Mangalore	Warm & Humid
Bhagalpur	Warm & Humid	Mumbai	Warm & Humid
Bhopal	Composite	Nagpur	Composite
Bhubaneshwar	Warm & Humid	Nellore	Warm & Humid
Bikaner	Hot & Dry	New Delhi	Composite
Chandigarh	Composite	Panjim	Warm & Humid
Chitradurga	Warm & Humid	Patna	Composite
Dehradun	Composite	Pune	Warm & Humid
Dibrugarh	Warm & Humid	Raipur	Composite
Guwahati	Warm & Humid	Rajkot	Composite
Gorakhpur	Composite	Ramgundam	Warm & Humid
Gwalior	Composite	Ranchi	Composite
Hissar	Composite	Ratnagiri	Warm & Humid
Hyderabad	Composite	Raxaul	Warm & Humid
Imphal	Warm & Humid	Saharanpur	Composite
Indore	Composite	Shillong	Cold
Jabalpur	Composite	Sholapur	Hot & Dry
Jagdelpur	Warm & Humid	Srinagar	Cold
Jaipur	Composite	Sundernagar	Cold
Jaisalmer	Hot & Dry	Surat	Hot & Dry
Jalandhar	Composite	Tezpur	Warm & Humid

Jamnagar	Warm & Humid	Tiruchirappalli	Warm & Humid
Jodhpur	Hot & Dry	Trivandrum	Warm & Humid
Jorhat	Warm & Humid	Tuticorin	Warm & Humid
Kochi	Warm & Humid	Udhagamandalam	Cold
Kolkata	Warm & Humid	Vadodara	Hot & Dry
Kota	Hot & Dry	Veraval	Warm & Humid
Kullu	Cold	Vishakhapatnam	Warm & Humid

DRAFT

## 6.2 Hot and Dry Climate

The climate of Hot and Dry climate zones is characterized by high temperatures at around 40-50°C, scarce rainfall and low humidity. The temperatures vary sharply during the day and night, and also across the seasons, thus winds and dust storms are prevalent throughout the year. Hot winds are replaced by cold winds during the winters. The solar radiation intensity is high with less diffused radiation due to clear sky conditions.

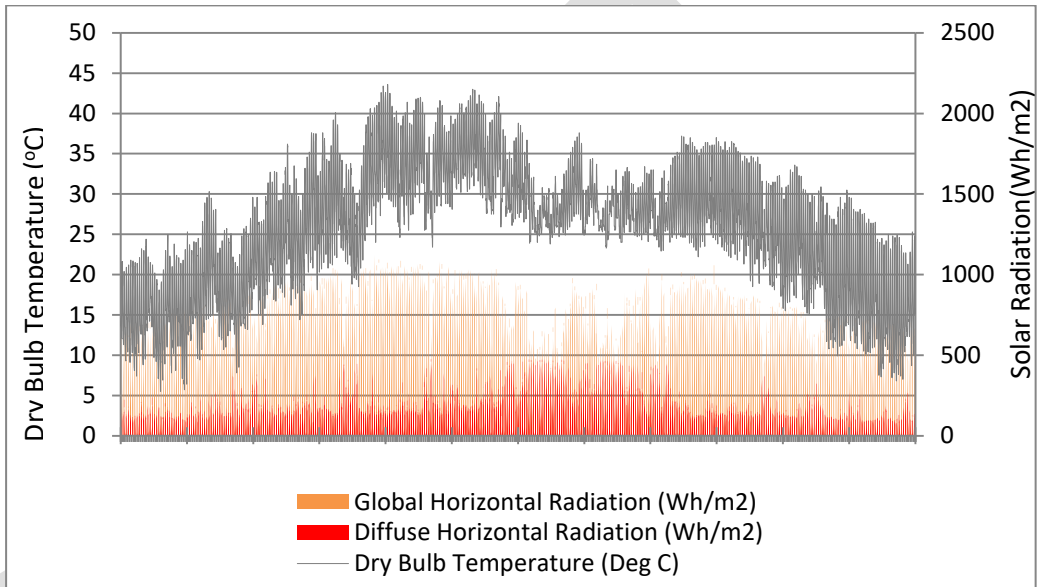

Figure 6- 1 Weather data for Jaipur (Hot and Dry Climate)

Table 6- B Design Guideline Matrix for Hot and Dry Climate Zone

	Building Element	Typology/Property	ECBC Compliance	ECBC+ Compliance	Super ECBC Compliance	Implementation (Reference)
BUILDING ENVELOPE	Roofs (Assembly U-Value- W/m2K)	All Building types, except below	0.33			Appendix D- R3, R5, R6
		School <10,000 m2 AGA	0.47			Appendix D- R3
		Hospitality >10,000 m2 AGA	0.20			Appendix D- R1, R4
		Hospitality, Healthcare, Assembly		0.20		Appendix D- R1, R4
		Business, Educational, Shopping Complex		0.26		Appendix D- R1, R2, R4
		All Building types			0.20	Appendix D- R1, R4
	Walls (Assembly U-Value- W/m2K)	All Building Types, except below	0.40	0.34		Appendix C-W1, W3, W5, W11, W12, W13, W15
		No Star Hotel <10,000 m2 AGA	0.63	0.44		Appendix C-W4, W6, W10
		Business <10,000 m2 AGA	0.63	0.44		Appendix C-W4, W6, W10
		School <10,000 m2 AGA	0.85	0.63		Appendix C-W2, W10
		All Building types			0.22	Appendix C-W7, W8, W9, W14

	Vertical Fenestration (without External Shading)	WWR	<40%	<40%	< 40%	
		VLT	< 0.27	<0.27	<0.27	
		U-Factor (W/m2K)	<3	<2.20	<2.20	
		SHGC – Non-North	0.27	0.25	0.25	
		SHGC – North for latitude ≥ 15°N	0.50	0.50	0.50	
		SHGC North for latitude < 15°N	0.27	0.25	0.25	
	Skylights	SRR	<5%	<5%	<5%	
		U-factor (W/m2K)	<4.25	<4.25	<4.25	
COMFORT SYSTEMS & CONTROLS		SHGC	0.35	0.35	0.35	
	Water Cooled Chillers (<260 kW <sub>r</sub> )	COP	4.7	5.2	5.8	
		IPLV	5.8	6.9	7.1	
	Water Cooled Chillers (≥260 & <1580 kW <sub>r</sub> )	COP	§0	§0	§0	
		IPLV				
	Air Cooled Chillers (<260 kW <sub>r</sub> )	COP	2.8	3.0	NA	
		IPLV	3.5	4.0		
	Air Cooled Chillers (≥260 kW <sub>r</sub> )	COP	3.0	3.2	NA	
		IPLV	3.7	5.0		
	Air-Cooled Unitary, Split, Packaged Air-conditioners	<10.5 kW <sub>r</sub>	BEE 3-Star	BEE 4-Star	BEE 5-Star	
>10.5 kW <sub>r</sub>		2.8 EER	3.2 EER	3.4 EER		

	Water-Cooled Unitary, Split, Packaged Air-conditioners	>10.5 kW <sub>r</sub>	3.3 EER	3.7 EER	3.9 EER	
	VRF		§5.1.1.7			
	Low-Energy Comfort Systems			§5.1.1.8 , §5.1.1.9 §5.1.1.10	§5.1.1.8 , §5.1.1.9 §5.1.1.10	
	Controls	Timeclock	§5.1.2.1	§5.1.2.1	§5.1.2.1	
		Temperature Controls	§5.1.2.2	§5.1.2.2	§5.1.2.2	
		Occupancy Controls	§5.1.2.3	§5.1.2.3	§5.1.2.3	
		Fan Controls	§5.1.2.4	§5.1.2.4	§5.1.2.4	
		Dampers	§5.1.2.5	§5.1.2.5	§5.1.2.5	
		Centralized Demand Shed Controls		§5.1.3.1	§5.1.3.1	
		Supply Air Temperature Reset		§5.1.3.2	§5.1.3.2	
		Chilled Water temperature reset		§5.1.3.3	§5.1.3.3	
		VAV Fan control			§5.1.4.1	
	Piping & Ductwork		APPENDIX E	APPENDIX E	APPENDIX E	
	AHU-Fans-Supply, Return & Exhaust	Mechanical Efficiency	60%	65%	70%	
		Motor Efficiency (As per IS 12615)	IE 2	IE 3	IE 4	
	Pump Efficiency	Chilled Water Pump (Primary & Secondary)	18.2 W/kW <sub>r</sub> with VFD on Secondary Pump	16.9 W/kW <sub>r</sub> with VFD on Secondary Pump	14.9 W/kW <sub>r</sub> with VFD on Secondary Pump	

		Condenser Water Pump	17.7 W/kW <sub>r</sub>	16.5 W/kW <sub>r</sub>	14.6 W/kW <sub>r</sub>	
		Pump Efficiency (minimum)	70%	75%	85%	
	Cooling Tower-Open Circuit Cooling Tower Fans	Rating Condition-35°C Entering Water	0.017 kW/kW <sub>r</sub>	0.017 kW/kW <sub>r</sub>	0.017 kW/kW <sub>r</sub>	
		Rating Condition-29°C Leaving Water	0.31 kW/L/s	0.31 kW/L/s	0.31 kW/L/s	
		Rating Condition-24°C WB Outdoor Air	0.31 kW/L/s	0.31 kW/L/s	0.31 kW/L/s	
	Economizers		§5.1.8	§5.1.8	§5.1.8	
	Boilers, Hot Water (Gas or Oil fired)-All Capacity	Minimum FUE	80%	85%	85%	
	Energy Recovery		§5.1.9	§5.1.9	§5.1.9	
	Service Water Heating		§5.1.7	§5.1.7	§5.1.7	
	Condensers		§5.1.6	§5.1.6	§5.1.6	
LIGHTING	Daylight (UDI <sup>2</sup> )	Business/Educational	40%	50%	60%	
		No Star Hotel/Star Hotel/ Healthcare	30%	40%	50%	
		Resort	45%	55%	65%	
		Shopping Complex	10%	15%	20%	

<sup>2</sup> Percentage of above grade floor area meeting the UDI requirement for 90% of the potential daylight time in a year

	Surface Reflectance	Wall or Vertical internal Surfaces	>50%	>50%	>50%	
		Ceiling	>70%	>70%	>70%	
		Floor	>20%	>20%	>20%	
		Furniture (permanent)	>50%	>50%	>50%	
	Interior Lighting	LPD	Appendix F- Table F- 1, Table F- 4	Appendix F- Table F- 2, Table F- 5	Appendix F- Table F- 3, Table F- 6	
		Luminaire Efficacy	>0.7	>0.7	>0.7	
		Lighting Controls	§5.2	§b)	§b)	
	Exterior Lighting	Power Limits-	Appendix F- Table F- 7	Appendix F- Table F- 8	Appendix F- Table F- 9	
ELECTRICAL		Transformers	§5.3.1	§5.3.1	§5.3.1	
		Motors	§5.3.2	§5.3.2	§5.3.2	
		DG Sets	§5.3.4	§5.3.4	§5.3.4	
		Power Factor Correction	§5.3.7	§5.3.7	§5.3.7	
		UPS	§5.3.5	§5.3.5	§5.3.5	
		Renewable Systems	§5.3.6	§5.3.6	§5.3.6	



## 6.3 Warm and Humid Climate

The climate of warm humid zones is characterized by relatively high temperatures at around 30-35°C, high rainfall and high humidity, 70-90% throughout the year. The temperatures remain even during the day and across the year, thus winds are light or absent for long durations. Since the humidity levels are high, heavy precipitation, being 1200 mm per year or more, and storms occur on a frequent basis. The solar radiation intensity is high with more diffused radiation due to high cloud cover.

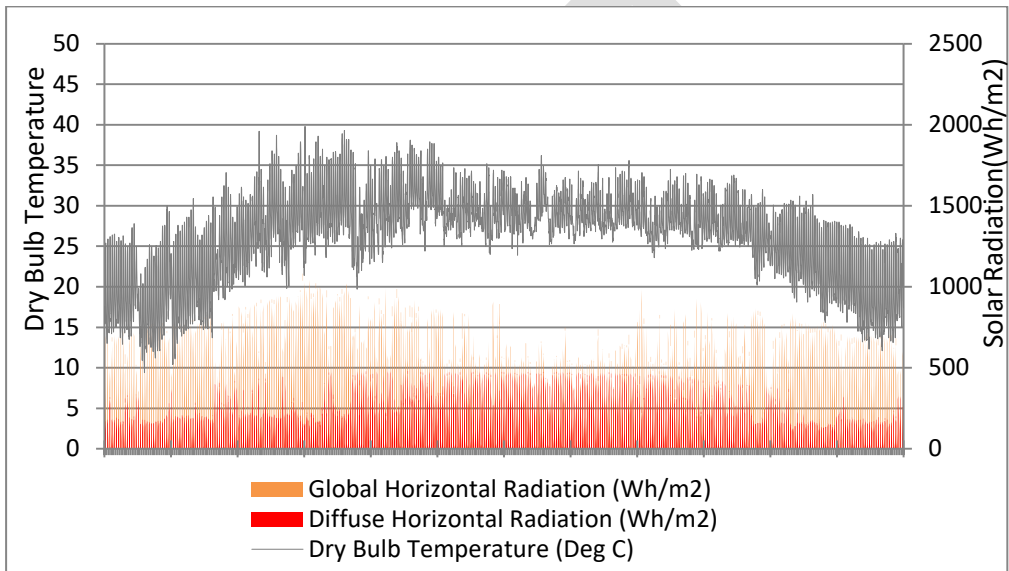

Figure 6- 2 Weather data for Kolkata (Warm and Humid Climate)

Table 6- C Design Guideline Matrix for Warm and Humid Climate Zone

	Building Element	Typology/Property	ECBC Compliance	ECBC+ Compliance	Super ECBC Compliance	Implementation (Reference)
BUILDING ENVELOPE	Roofs (Assembly U-Value- W/m2K)	All Building types, except below	0.33			Appendix D- R3, R5, R6
		School<10,000 m2 AGA	0.47			Appendix D- R3
		Hospitality >10,000 m2 AGA	0.20			Appendix D- R1, R4
		Hospitality, Healthcare, Assembly		0.20		Appendix D- R1, R4
		Business, Educational, Shopping Complex		0.26		Appendix D- R1, R2, R4
		All Building types			0.20	Appendix D- R1, R4
	Walls (Assembly U-Value- W/m2K)	All Building Types, except below	0.40	0.34		Appendix C-W1, W3, W5, W11, W12, W13, W15
		No Star Hotel <10,000 m2 AGA	0.63	0.44		Appendix C-W4, W6, W10
		Business <10,000 m2 AGA	0.63	0.44		Appendix C-W4, W6, W10
		School <10,000 m2 AGA	0.85	0.63		Appendix C-W2, W10
		All Building types			0.22	Appendix C-W7, W8, W9,W14

	Vertical Fenestration (without External Shading)	WWR	<40%	<40%	< 40%	
		VLT	< 0.27	<0.27	<0.27	
		U-Factor (W/m2K)	<3	<2.20	<2.20	
		SHGC – Non-North	0.27	0.25	0.25	
		SHGC – North for latitude ≥ 15°N	0.50	0.50	0.50	
		SHGC North for latitude < 15°N	0.27	0.25	0.25	
	Skylights	SRR	<5%	<5%	<5%	
		U-factor (W/m2K)	<4.25	<4.25	<4.25	
		SHGC	0.35	0.35	0.35	
COMFORT SYSTEMS & CONTROLS	Water Cooled Chillers (<260 kW <sub>r</sub> )	COP	4.7	5.2	5.8	
		IPLV	5.8	6.9	7.1	
	Water Cooled Chillers (≥260 & <1580 kW <sub>r</sub> )	COP	§0	§0	§0	
		IPLV				
	Air Cooled Chillers (<260 kW <sub>r</sub> )	COP	2.8	3.0	NA	
		IPLV	3.5	4.0		
	Air Cooled Chillers (≥260 kW <sub>r</sub> )	COP	3.0	3.2	NA	
		IPLV	3.7	5.0		
	Air-Cooled Unitary, Split, Packaged Air-conditioners	<10.5 kW <sub>r</sub>	BEE 3-Star	BEE 4-Star	BEE 5-Star	
		>10.5 kW <sub>r</sub>	2.8 EER	3.2 EER	3.4 EER	

	Water-Cooled Unitary, Split, Packaged Air-conditioners	>10.5 kW <sub>r</sub>	3.3 EER	3.7 EER	3.9 EER	
	VRF		§5.1.1.7			
	Low-Energy Comfort Systems			§5.1.1.8 , §5.1.1.9 §5.1.1.10	§5.1.1.8 , §5.1.1.9 §5.1.1.10	
	Controls	Timeclock	§5.1.2.1	§5.1.2.1	§5.1.2.1	
		Temperature Controls	§5.1.2.2	§5.1.2.2	§5.1.2.2	
		Occupancy Controls	§5.1.2.3	§5.1.2.3	§5.1.2.3	
		Fan Controls	§5.1.2.4	§5.1.2.4	§5.1.2.4	
		Dampers	§5.1.2.5	§5.1.2.5	§5.1.2.5	
		Centralized Demand Shed Controls		§5.1.3.1	§5.1.3.1	
		Supply Air Temperature Reset		§5.1.3.2	§5.1.3.2	
		Chilled Water temperature reset		§5.1.3.3	§5.1.3.3	
		VAV Fan control			§5.1.4.1	
	Piping & Ductwork		APPENDIX E	APPENDIX E	APPENDIX E	
	AHU-Fans-Supply, Return & Exhaust	Mechanical Efficiency	60%	65%	70%	
		Motor Efficiency (As per IS 12615)	IE 2	IE 3	IE 4	
	Pump Efficiency	Chilled Water Pump (Primary & Secondary)	18.2 W/kW <sub>r</sub> with VFD on Secondary Pump	16.9 W/kW <sub>r</sub> with VFD on Secondary Pump	14.9 W/kW <sub>r</sub> with VFD on Secondary Pump	

		Condenser Water Pump	17.7 W/kW <sub>r</sub>	16.5 W/kW <sub>r</sub>	14.6 W/kW <sub>r</sub>	
		Pump Efficiency (minimum)	70%	75%	85%	
	Cooling Tower-Open Circuit Cooling Tower Fans	Rating Condition-35°C Entering Water	0.017 kW/kW <sub>r</sub>	0.017 kW/kW <sub>r</sub>	0.017 kW/kW <sub>r</sub>	
		Rating Condition-29°C Leaving Water	0.31 kW/L/s	0.31 kW/L/s	0.31 kW/L/s	
		Rating Condition-24°C WB Outdoor Air	0.31 kW/L/s	0.31 kW/L/s	0.31 kW/L/s	
	Economizers		§5.1.8	§5.1.8	§5.1.8	
	Boilers, Hot Water (Gas or Oil fired)-All Capacity	Minimum FUE	80%	85%	85%	
	Energy Recovery		§5.1.9	§5.1.9	§5.1.9	
	Service Water Heating		§5.1.7	§5.1.7	§5.1.7	
	Condensers		§5.1.6	§5.1.6	§5.1.6	
LIGHTING	Daylight (UDI <sup>3</sup> )	Business/Educational	40%	50%	60%	
		No Star Hotel/Star Hotel/ Healthcare	30%	40%	50%	
		Resort	45%	55%	65%	
		Shopping Complex	10%	15%	20%	

<sup>3</sup> Percentage of above grade floor area meeting the UDI requirement for 90% of the potential daylight time in a year

	Surface Reflectance	Wall or Vertical internal Surfaces	>50%	>50%	>50%	
		Ceiling	>70%	>70%	>70%	
		Floor	>20%	>20%	>20%	
		Furniture (permanent)	>50%	>50%	>50%	
	Interior Lighting	LPD	Appendix F- Table F- 1, Table F- 4	Appendix F- Table F- 2, Table F- 5	Appendix F- Table F- 3, Table F- 6	
		Luminaire Efficacy	>0.7	>0.7	>0.7	
		Lighting Controls	§5.2	§b)	§b)	
	Exterior Lighting	Power Limits-	Appendix F- Table F- 7	Appendix F- Table F- 8	Appendix F- Table F- 9	
ELECTRICAL		Transformers	§5.3.1	§5.3.1	§5.3.1	
		Motors	§5.3.2	§5.3.2	§5.3.2	
		DG Sets	§5.3.4	§5.3.4	§5.3.4	
		Power Factor Correction	§5.3.7	§5.3.7	§5.3.7	
		UPS	§5.3.5	§5.3.5	§5.3.5	
		Renewable Systems	§5.3.6	§5.3.6	§5.3.6	

DRAFT

## 6.4 Temperate Climate

The climate of Temperate zones is characterized by moderate temperatures at around 30-34°C during the day and 17-24°C at night. In winters, the maximum temperature reaches 33°C during the day and 18°C at night. High humidity between 55-90% during the monsoons, whereas, humidity remains low at 20-55% during the rest of the months. . Since the humidity levels are high in monsoons, heavy precipitation, exceeding 1000 mm per year is experienced The temperatures vary during the day in summers, thus winds are high. The solar radiation intensity is high with more direct radiation due to clear sky conditions

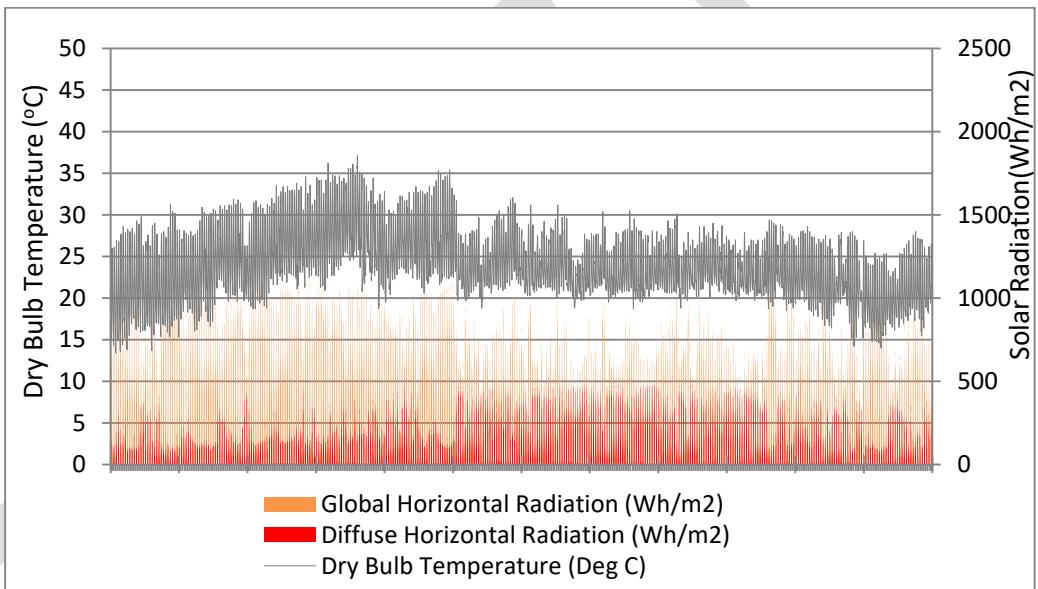

Figure 6- 3 Weather data for Bengaluru (Temperate Climate)



Table 6- D Design Guideline Matrix for Temperate Climate Zone

	Building Element	Typology/Property	ECBC Compliance	ECBC+ Compliance	Super ECBC Compliance	Implementation (Reference)
BUILDING ENVELOPE	Roofs (Assembly U-Value- W/m2K)	All Building types, except below	0.33			Appendix D- R3, R5, R6
		School<10,000 m2 AGA	0.47			Appendix D- R3
		Hospitality >10,000 m2 AGA	0.20			Appendix D- R1, R4
		Hospitality, Healthcare, Assembly		0.20		Appendix D- R1, R4
		Business, Educational, Shopping Complex		0.26		Appendix D- R1, R2, R4
		All Building types			0.20	Appendix D- R1, R4
	Walls (Assembly U-Value- W/m2K)	All Building Types, except below	0.55	0.55		Appendix C- W4,W6
		No Star Hotel <10,000 m2 AGA	0.63	0.44		Appendix C-W3, W4, W6, W10, W11
		Business <10,000 m2 AGA	0.63	0.55		Appendix C-W4, W6, W10
		School <10,000 m2 AGA	1.00	0.75		Appendix C-W2, W10
		All Building types			0.22	Appendix C-W7, W8, W9,W14

	Vertical Fenestration (without External Shading)	WWR	<40%	<40%	< 40%		
		VLT	< 0.27	<0.27	<0.27		
		U-Factor (W/m2K)	<3	<2.20	<2.20		
		SHGC – Non-North	0.27	0.25	0.25		
		SHGC – North for latitude ≥ 15°N	0.50	0.50	0.50		
		SHGC North for latitude < 15°N	0.27	0.25	0.25		
		Skylights	SRR	<5%	<5%	<5%	
			U-factor (W/m2K)	<4.25	<4.25	<4.25	
COMFORT SYSTEMS & CONTROLS	Water Cooled Chillers (<260 kW <sub>r</sub> )	COP	4.7	5.2	5.8		
		IPLV	5.8	6.9	7.1		
	Water Cooled Chillers (≥260 & <1580 kW <sub>r</sub> )	COP	§0	§0	§0		
		IPLV					
	Air Cooled Chillers (<260 kW <sub>r</sub> )	COP	2.8	3.0	NA		
		IPLV	3.5	4.0			
	Air Cooled Chillers (≥260 kW <sub>r</sub> )	COP	3.0	3.2	NA		
		IPLV	3.7	5.0			
	Air-Cooled Unitary, Split, Packaged Air-conditioners	<10.5 kW <sub>r</sub>	BEE 3-Star	BEE 4-Star	BEE 5-Star		
		>10.5 kW <sub>r</sub>	2.8 EER	3.2 EER	3.4 EER		

	Water-Cooled Unitary, Split, Packaged Air-conditioners	>10.5 kW <sub>r</sub>	3.3 EER	3.7 EER	3.9 EER	
	VRF		§5.1.1.7			
	Low-Energy Comfort Systems			§5.1.1.8 , §5.1.1.9 §5.1.1.10	§5.1.1.8 , §5.1.1.9 §5.1.1.10	
	Controls	Timeclock	§5.1.2.1	§5.1.2.1	§5.1.2.1	
		Temperature Controls	§5.1.2.2	§5.1.2.2	§5.1.2.2	
		Occupancy Controls	§5.1.2.3	§5.1.2.3	§5.1.2.3	
		Fan Controls	§5.1.2.4	§5.1.2.4	§5.1.2.4	
		Dampers	§5.1.2.5	§5.1.2.5	§5.1.2.5	
		Centralized Demand Shed Controls		§5.1.3.1	§5.1.3.1	
		Supply Air Temperature Reset		§5.1.3.2	§5.1.3.2	
		Chilled Water temperature reset		§5.1.3.3	§5.1.3.3	
		VAV Fan control			§5.1.4.1	
	Piping & Ductwork		APPENDIX E	APPENDIX E	APPENDIX E	
	AHU-Fans-Supply, Return & Exhaust	Mechanical Efficiency	60%	65%	70%	
		Motor Efficiency (As per IS 12615)	IE 2	IE 3	IE 4	
	Pump Efficiency	Chilled Water Pump (Primary & Secondary)	18.2 W/kW <sub>r</sub> with VFD on Secondary Pump	16.9 W/kW <sub>r</sub> with VFD on Secondary Pump	14.9 W/kW <sub>r</sub> with VFD on Secondary Pump	

		Condenser Water Pump	17.7 W/kW <sub>r</sub>	16.5 W/kW <sub>r</sub>	14.6 W/kW <sub>r</sub>	
		Pump Efficiency (minimum)	70%	75%	85%	
	Cooling Tower-Open Circuit Cooling Tower Fans	Rating Condition-35°C Entering Water	0.017 kW/kW <sub>r</sub>	0.017 kW/kW <sub>r</sub>	0.017 kW/kW <sub>r</sub>	
		Rating Condition-29°C Leaving Water	0.31 kW/L/s	0.31 kW/L/s	0.31 kW/L/s	
		Rating Condition-24°C WB Outdoor Air	0.31 kW/L/s	0.31 kW/L/s	0.31 kW/L/s	
	Economizers		§5.1.8	§5.1.8	§5.1.8	
	Boilers, Hot Water (Gas or Oil fired)-All Capacity	Minimum FUE	80%	85%	85%	
	Energy Recovery		§5.1.9	§5.1.9	§5.1.9	
	Service Water Heating		§5.1.7	§5.1.7	§5.1.7	
	Condensers		§5.1.6	§5.1.6	§5.1.6	
LIGHTING	Daylight (UDI <sup>4</sup> )	Business/Educational	40%	50%	60%	
		No Star Hotel/Star Hotel/ Healthcare	30%	40%	50%	
		Resort	45%	55%	65%	
		Shopping Complex	10%	15%	20%	

<sup>4</sup> Percentage of above grade floor area meeting the UDI requirement for 90% of the potential daylight time in a year

	Surface Reflectance	Wall or Vertical internal Surfaces	>50%	>50%	>50%	
		Ceiling	>70%	>70%	>70%	
		Floor	>20%	>20%	>20%	
		Furniture (permanent)	>50%	>50%	>50%	
	Interior Lighting	LPD	Appendix F- Table F- 1, Table F- 4	Appendix F- Table F- 2, Table F- 5	Appendix F- Table F- 3, Table F- 6	
		Luminaire Efficacy	>0.7	>0.7	>0.7	
		Lighting Controls	§5.2	§b)	§b)	
	Exterior Lighting	Power Limits-	Appendix F- Table F- 7	Appendix F- Table F- 8	Appendix F- Table F- 9	
ELECTRICAL		Transformers	§5.3.1	§5.3.1	§5.3.1	
		Motors	§5.3.2	§5.3.2	§5.3.2	
		DG Sets	§5.3.4	§5.3.4	§5.3.4	
		Power Factor Correction	§5.3.7	§5.3.7	§5.3.7	
		UPS	§5.3.5	§5.3.5	§5.3.5	
		Renewable Systems	§5.3.6	§5.3.6	§5.3.6	

## 6.5 Composite Climate

The composite climatic zone is characterized by large seasonal variations. The peak temperatures reach a maximum of 32-43°C during daytime in summers and cold winters with temperatures between 4 to 10°C at night. Similarly a high contrast in humidity is experienced in the dry and monsoon periods, with relative humidity rising up to 95% in the wet period.

The temperatures show diurnal variation between 10-12°C during the day, thus winds are hot and dusty during the summers and dry cold winds during the winters. The regions experience heavy precipitation, between 500- 1300 mm per year or more. The solar radiation intensity is high with more diffused radiation due to high cloud cover during the monsoon, hazy in summers and clear in winters.

The main difference between, composite regions and hot dry zones is higher humidity levels during monsoons, otherwise most of the characteristics are similar. Thus, the design criteria is almost similar except that cross-ventilation is desirable in the monsoon period.

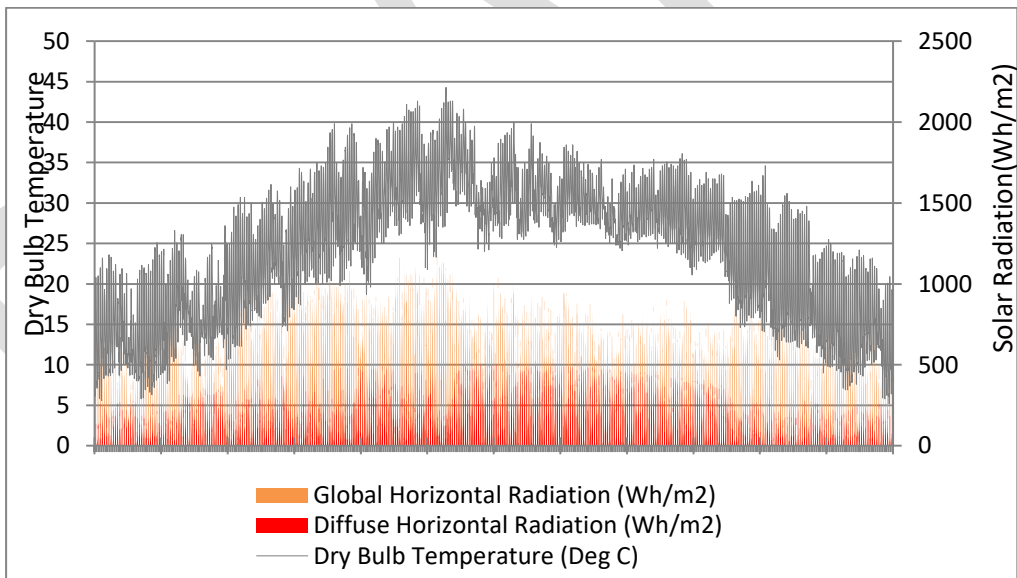

Figure 6- 4 Weather data for New Delhi (Composite Climate)

Table 6- E Design Guideline Matrix for Composite Climate Zone

	Building Element	Typology/Property	ECBC Compliance	ECBC+ Compliance	Super ECBC Compliance	Implementation (Reference)
BUILDING ENVELOPE	Roofs (Assembly U-Value- W/m2K)	All Building types, except below	0.33			Appendix D- R3, R5, R6
		School<10,000 m2 AGA	0.47			Appendix D- R3
		Hospitality >10,000 m2 AGA	0.20			Appendix D- R1, R4
		Hospitality, Healthcare, Assembly		0.20		Appendix D- R1, R4
		Business, Educational, Shopping Complex		0.26		Appendix D- R1, R2, R4
		All Building types			0.20	Appendix D- R1, R4
	Walls (Assembly U-Value- W/m2K)	All Building Types, except below	0.40	0.34		Appendix C-W1, W3, W5, W11, W12, W13, W15
		No Star Hotel <10,000 m2 AGA	0.63	0.44		Appendix C-W4, W6, W10
		Business <10,000 m2 AGA	0.63	0.44		Appendix C-W4, W6, W10
		School <10,000 m2 AGA	0.85	0.63		Appendix C-W2, W10
		All Building types			0.22	Appendix C-W7, W8, W9,W14

	Vertical Fenestration (without External Shading)	WWR	<40%	<40%	< 40%		
		VLT	< 0.27	<0.27	<0.27		
		U-Factor (W/m2K)	<3	<2.20	<2.20		
		SHGC – Non-North	0.27	0.25	0.25		
		SHGC – North for latitude ≥ 15°N	0.50	0.50	0.50		
		SHGC North for latitude < 15°N	0.27	0.25	0.25		
		Skylights	SRR	<5%	<5%	<5%	
			U-factor (W/m2K)	<4.25	<4.25	<4.25	
COMFORT SYSTEMS & CONTROLS	Water Cooled Chillers (<260 kW <sub>r</sub> )	COP	4.7	5.2	5.8		
		IPLV	5.8	6.9	7.1		
	Water Cooled Chillers (≥260 & <1580 kW <sub>r</sub> )	COP	§0	§0	§0		
		IPLV					
	Air Cooled Chillers (<260 kW <sub>r</sub> )	COP	2.8	3.0	NA		
		IPLV	3.5	4.0			
	Air Cooled Chillers (≥260 kW <sub>r</sub> )	COP	3.0	3.2	NA		
		IPLV	3.7	5.0			
	Air-Cooled Unitary, Split, Packaged Air-conditioners	<10.5 kW <sub>r</sub>	BEE 3-Star	BEE 4-Star	BEE 5-Star		
		>10.5 kW <sub>r</sub>	2.8 EER	3.2 EER	3.4 EER		



	Water-Cooled Unitary, Split, Packaged Air-conditioners	>10.5 kW <sub>r</sub>	3.3 EER	3.7 EER	3.9 EER	
	VRF		§5.1.1.7			
	Low-Energy Comfort Systems			§5.1.1.8 , §5.1.1.9 §5.1.1.10	§5.1.1.8 , §5.1.1.9 §5.1.1.10	
	Controls	Timeclock	§5.1.2.1	§5.1.2.1	§5.1.2.1	
		Temperature Controls	§5.1.2.2	§5.1.2.2	§5.1.2.2	
		Occupancy Controls	§5.1.2.3	§5.1.2.3	§5.1.2.3	
		Fan Controls	§5.1.2.4	§5.1.2.4	§5.1.2.4	
		Dampers	§5.1.2.5	§5.1.2.5	§5.1.2.5	
		Centralized Demand Shed Controls		§5.1.3.1	§5.1.3.1	
		Supply Air Temperature Reset		§5.1.3.2	§5.1.3.2	
		Chilled Water temperature reset		§5.1.3.3	§5.1.3.3	
		VAV Fan control			§5.1.4.1	
	Piping & Ductwork		APPENDIX E	APPENDIX E	APPENDIX E	
	AHU-Fans-Supply, Return & Exhaust	Mechanical Efficiency	60%	65%	70%	
		Motor Efficiency (As per IS 12615)	IE 2	IE 3	IE 4	
	Pump Efficiency	Chilled Water Pump (Primary & Secondary)	18.2 W/kW <sub>r</sub> with VFD on Secondary Pump	16.9 W/kW <sub>r</sub> with VFD on Secondary Pump	14.9 W/kW <sub>r</sub> with VFD on Secondary Pump	

		Condenser Water Pump	17.7 W/kW <sub>r</sub>	16.5 W/kW <sub>r</sub>	14.6 W/kW <sub>r</sub>	
		Pump Efficiency (minimum)	70%	75%	85%	
	Cooling Tower- Open Circuit Cooling Tower Fans	Rating Condition- 35°C Entering Water	0.017 kW/kW <sub>r</sub>	0.017 kW/kW <sub>r</sub>	0.017 kW/kW <sub>r</sub>	
		Rating Condition- 29°C Leaving Water	0.31 kW/L/s	0.31 kW/L/s	0.31 kW/L/s	
		Rating Condition- 24°C WB Outdoor Air	0.31 kW/L/s	0.31 kW/L/s	0.31 kW/L/s	
	Economizers		§5.1.8	§5.1.8	§5.1.8	
	Boilers, Hot Water (Gas or Oil fired)- All Capacity	Minimum FUE	80%	85%	85%	
	Energy Recovery		§5.1.9	§5.1.9	§5.1.9	
	Service Water Heating		§5.1.7	§5.1.7	§5.1.7	
	Condensers		§5.1.6	§5.1.6	§5.1.6	
LIGHTING	Daylight (UDI <sup>5</sup> )	Business/Educational	40%	50%	60%	
		No Star Hotel/Star Hotel/ Healthcare	30%	40%	50%	
		Resort	45%	55%	65%	
		Shopping Complex	10%	15%	20%	

<sup>5</sup> Percentage of above grade floor area meeting the UDI requirement for 90% of the potential daylight time in a year

	Surface Reflectance	Wall or Vertical internal Surfaces	>50%	>50%	>50%	
		Ceiling	>70%	>70%	>70%	
		Floor	>20%	>20%	>20%	
		Furniture (permanent)	>50%	>50%	>50%	
	Interior Lighting	LPD	Appendix F- Table F- 1, Table F- 4	Appendix F- Table F- 2, Table F- 5	Appendix F- Table F- 3, Table F- 6	
		Luminaire Efficacy	>0.7	>0.7	>0.7	
		Lighting Controls	§5.2	§b)	§b)	
	Exterior Lighting	Power Limits-	Appendix F- Table F- 7	Appendix F- Table F- 8	Appendix F- Table F- 9	
ELECTRICAL		Transformers	§5.3.1	§5.3.1	§5.3.1	
		Motors	§5.3.2	§5.3.2	§5.3.2	
		DG Sets	§5.3.4	§5.3.4	§5.3.4	
		Power Factor Correction	§5.3.7	§5.3.7	§5.3.7	
		UPS	§5.3.5	§5.3.5	§5.3.5	
		Renewable Systems	§5.3.6	§5.3.6	§5.3.6	

## 6.6 Cold Climate

The northern hilly regions of India are covered under this climatic zone. The zone can further be categorized into:

- **Cold and Cloudy** : The climate of this zone is characterized by chilly winters and pleasant summer conditions. During the winter months, the maximum temperature ranges between 4 to 8°C during the day and dips to -3°C at night. The intensity of solar radiation is low with more diffused radiation, making the ambient temperatures lower. In the absence of the solar radiation, the relative humidity is generally high at 70 – 80%. The region experiences heavy precipitation of 1000 mm or more across the year and cold winds during the winter period.
- **Cold and Sunny** : The climate of this zone is characterized by chilly winters with intense solar radiation and predominant in the high altitude regions North India, also termed as 'Cold Desert'. During the winter months, the maximum temperature ranges between -7 to 8°C during the day and dips to -14°C at night. The region is dry with relative humidity is low at 10 – 50% and very low precipitation, less than, 200 mm per year and occasional intense winds. The sky is mostly clear with less than 50% cloud cover throughout the year.

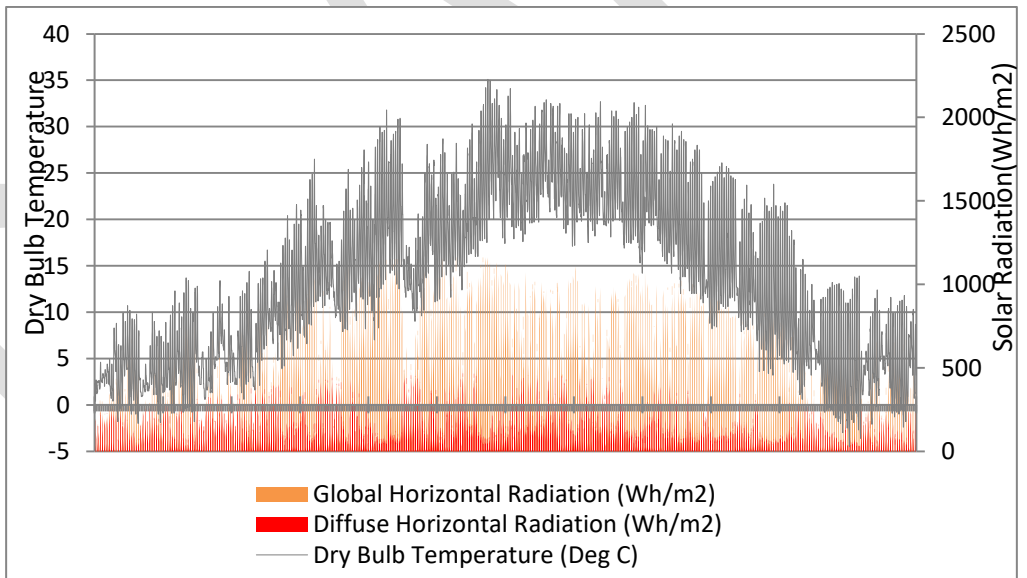

Figure 6- 5 Weather data for Srinagar (Cold Climate)

Table 6- F Design Guideline Matrix for Cold Climate Zone

	Building Element	Typology/Property	ECBC Compliance	ECBC+ Compliance	Super ECBC Compliance	Implementation (Reference)
BUILDING ENVELOPE	Roofs (Assembly U-Value- W/m2K)	All Building types, except below	0.28			Appendix D- R3, R5, R6
		School<10,000 m2 AGA	0.33			Appendix D- R3
		Hospitality >10,000 m2 AGA	0.20			Appendix D- R1, R4
		Hospitality, Healthcare, Assembly		0.20		Appendix D- R1, R4
		Business, Educational, Shopping Complex		0.20		Appendix D- R1, R2, R4
		All Building types			0.20	Appendix D- R1, R4
	Walls (Assembly U-Value- W/m2K)	All Building Types, except below	0.34	0.22		Appendix C-W1, W3, W5, W11, W12, W13, W15
		No Star Hotel <10,000 m2 AGA	0.40	0.34		Appendix C-W4, W6, W10
		Business <10,000 m2 AGA	0.40	0.34		Appendix C-W4, W6, W10
		School <10,000 m2 AGA	0.40	0.44		Appendix C-W2, W10

		All Building types			0.22	Appendix C-W7, W8, W9,W14
	Vertical Fenestration (without External Shading)	WWR	<40%	<40%	< 40%	
		VLT	< 0.27	<0.27	<0.27	
		U-Factor (W/m2K)	<3	<1.80	<1.80	
		SHGC – Non-North	0.62	0.62	0.62	
		SHGC – North for latitude ≥ 15°N	0.62	0.62	0.62	
		SHGC North for latitude < 15°N	0.62	0.62	0.62	
	Skylights	SRR	<5%	<5%	<5%	
		U-factor (W/m2K)	<4.25	<4.25	<4.25	
		SHGC	0.35	0.35	0.35	
	Water Cooled Chillers (<260 kW <sub>r</sub> )	COP	4.7	5.2	5.8	
		IPLV	5.8	6.9	7.1	
		COP	§0	§0	§0	

COMFORT SYSTEMS & CONTROLS	Water Cooled Chillers (≥260 & <1580 kW <sub>r</sub> )	IPLV				
	Air Cooled Chillers (<260 kW <sub>r</sub> )	COP	2.8	3.0	NA	
		IPLV	3.5	4.0		
	Air Cooled Chillers (≥260 kW <sub>r</sub> )	COP	3.0	3.2	NA	
		IPLV	3.7	5.0		
	Air-Cooled Unitary, Split, Packaged Air-conditioners	<10.5 kW <sub>r</sub>	BEE 3-Star	BEE 4-Star	BEE 5-Star	
		>10.5 kW <sub>r</sub>	2.8 EER	3.2 EER	3.4 EER	
	Water-Cooled Unitary, Split, Packaged Air-conditioners	>10.5 kW <sub>r</sub>	3.3 EER	3.7 EER	3.9 EER	
	VRF		§5.1.1.7			
	Low-Energy Comfort Systems			§5.1.1.8 , §5.1.1.9 §5.1.1.10	§5.1.1.8 , §5.1.1.9 §5.1.1.10	
	Controls	Timeclock	§5.1.2.1	§5.1.2.1	§5.1.2.1	
		Temperature Controls	§5.1.2.2	§5.1.2.2	§5.1.2.2	
		Occupancy Controls	§5.1.2.3	§5.1.2.3	§5.1.2.3	
		Fan Controls	§5.1.2.4	§5.1.2.4	§5.1.2.4	
		Dampers	§5.1.2.5	§5.1.2.5	§5.1.2.5	
Centralized Demand Shed Controls			§5.1.3.1	§5.1.3.1		
Supply Air Temperature Reset			§5.1.3.2	§5.1.3.2		

		Chilled Water temperature reset		§5.1.3.3	§5.1.3.3	
		VAV Fan control			§5.1.4.1	
Piping & Ductwork			APPENDIX E	APPENDIX E	APPENDIX E	
AHU-Fans-Supply, Return & Exhaust		Mechanical Efficiency	60%	65%	70%	
		Motor Efficiency (As per IS 12615)	IE 2	IE 3	IE 4	
Pump Efficiency		Chilled Water Pump (Primary & Secondary)	18.2 W/kW <sub>r</sub> with VFD on Secondary Pump	16.9 W/kW <sub>r</sub> with VFD on Secondary Pump	14.9 W/kW <sub>r</sub> with VFD on Secondary Pump	
		Condenser Water Pump	17.7 W/kW <sub>r</sub>	16.5 W/kW <sub>r</sub>	14.6 W/kW <sub>r</sub>	
		Pump Efficiency (minimum)	70%	75%	85%	
Cooling Tower- Open Circuit Cooling Tower Fans		Rating Condition- 35°C Entering Water	0.017 kW/kW <sub>r</sub>	0.017 kW/kW <sub>r</sub>	0.017 kW/kW <sub>r</sub>	
		Rating Condition- 29°C Leaving Water	0.31 kW/L/s	0.31 kW/L/s	0.31 kW/L/s	
		Rating Condition- 24°C WB Outdoor Air	0.31 kW/L/s	0.31 kW/L/s	0.31 kW/L/s	
Economizers			§5.1.8	§5.1.8	§5.1.8	
Boilers, Hot Water (Gas or Oil fired)- All Capacity		Minimum FUE	80%	85%	85%	



	Energy Recovery		§5.1.9	§5.1.9	§5.1.9	
	Service Water Heating		§5.1.7	§5.1.7	§5.1.7	
	Condensers		§5.1.6	§5.1.6	§5.1.6	
LIGHTING	Daylight (UDI <sup>6</sup> )	Business/Educational	40%	50%	60%	
		No Star Hotel/Star Hotel/ Healthcare	30%	40%	50%	
		Resort	45%	55%	65%	
		Shopping Complex	10%	15%	20%	
	Surface Reflectance	Wall or Vertical internal Surfaces	>50%	>50%	>50%	
		Ceiling	>70%	>70%	>70%	
		Floor	>20%	>20%	>20%	
		Furniture (permanent)	>50%	>50%	>50%	
	Interior Lighting	LPD	Appendix F- Table F- 1, Table F- 4	Appendix F- Table F- 2, Table F- 5	Appendix F- Table F- 3, Table F- 6	
		Luminaire Efficacy	>0.7	>0.7	>0.7	
	Lighting Controls	§5.2	§b)	§b)		

<sup>6</sup> Percentage of above grade floor area meeting the UDI requirement for 90% of the potential daylight time in a year

	Exterior Lighting	Power Limits-	Appendix F- Table F- 7	Appendix F- Table F- 8	Appendix F- Table F- 9	
ELECTRICAL		Transformers	§5.3.1	§5.3.1	§5.3.1	
		Motors	§5.3.2	§5.3.2	§5.3.2	
		DG Sets	§5.3.4	§5.3.4	§5.3.4	
		Power Factor Correction	§5.3.7	§5.3.7	§5.3.7	
		UPS	§5.3.5	§5.3.5	§5.3.5	
		Renewable Systems	§5.3.6	§5.3.6	§5.3.6	

DRAFT

# APPENDICES

## APPENDIX A

Table A- 1 Maximum Allowed EPI Ratios for Building in Composite Climate

Building Type	Composite		
	ECBC	ECBC +	Super-ECBC
Hotel (No Star and Star)	1	0.91	0.81
Resort	1	0.88	0.76
Hospital	1	0.85	0.77
Outpatient	1	0.85	0.75
Assembly	1	0.86	0.77
Office (Regular Use)	1	0.86	0.78
Office (24Hours)	1	0.88	0.76
Schools and University	1	0.77	0.66
Open Gallery Mall	1	0.85	0.76
Shopping Mall	1	0.86	0.74
Supermarket	1	0.81	0.70
Strip retail	1	0.82	0.68

Table A- 2 Maximum Allowed EPI Ratios for Building in Hot and Dry Climate

Building Type	Hot and Dry Climate		
	ECBC	ECBC +	Super-ECBC
Hotel (No Star and Star)	1	0.90	0.81
Resort	1	0.88	0.76
Hospital	1	0.84	0.76
Outpatient	1	0.85	0.75

Assembly	1	0.86	0.78
Office (Regular Use)	1	0.86	0.78
Office (24Hours)	1	0.88	0.76
Schools and University	1	0.77	0.66
Open Gallery Mall	1	0.85	0.77
Shopping Mall	1	0.84	0.72
Supermarket	1	0.73	0.69
Strip retail	1	0.82	0.68

*Table A- 3 Maximum Allowed EPI Ratios for Building in Temperate Climate*

<b>Building Type</b>	<b>Temperate Climate</b>		
	ECBC	ECBC +	Super-ECBC
Hotel (No Star and Star)	1	0.90	0.80
Resort	1	0.88	0.75
Hospital	1	0.82	0.73
Outpatient	1	0.85	0.75
Assembly	1	0.85	0.76
Office (Regular Use)	1	0.85	0.75
Office (24Hours)	1	0.87	0.74
Schools and University	1	0.77	0.66
Open Gallery Mall	1	0.83	0.74
Shopping Mall	1	0.84	0.71
Supermarket	1	0.81	0.69
Strip retail	1	0.81	0.67

Table A- 4 Maximum Allowed EPI Ratios for Building in Warm and Humid Climate

	Warm and Humid Climate		
<b>Building Type</b>	ECBC	ECBC +	Super-ECBC
Hotel (No Star and Star)	1	0.91	0.81
Resort	1	0.88	0.75
Hospital	1	0.86	0.77
Outpatient	1	0.86	0.76
Assembly	1	0.88	0.80
Office (Regular Use)	1	0.86	0.76
Office (24Hours)	1	0.88	0.76
Schools and University	1	0.77	0.66
Open Gallery Mall	1	0.86	0.77
Shopping Mall	1	0.85	0.72
Supermarket	1	0.82	0.70
Strip retail	1	0.83	0.68

Table A- 5 Maximum Allowed EPI Ratios for Building in Cold Climate

	Cold Climate		
<b>Building Type</b>	ECBC	ECBC +	Super-ECBC
Hotel (No Star and Star)	1	0.91	0.82
Resort	1	0.88	0.75
Hospital	1	0.88	0.80

Outpatient	1	0.85	0.75
Assembly	1	0.87	0.81
Office (Regular Use)	1	0.88	0.80
Office (24Hours)	1	0.87	0.75
Schools and University	1	0.85	0.73
Open Gallery Mall	1	0.82	0.73
Shopping Mall	1	0.96	0.93
Supermarket	1	0.80	0.68
Strip retail	1	0.80	0.66



DRAFT

## Appendix B

### BASICS FOR U-VALUE CALCULATION –

To calculate the U-Value for any wall assembly, the following parameters of all the constituting materials are required -

#### a. Thermal Conductivity of the material/s – Lamda value ( $\lambda$ )

Thermal conductivity (also known as Lambda) is the rate at which heat passes through a material, measured in watts per square meter of surface area for a temperature gradient of one kelvin for every meter thickness. This is expressed as W/mK. Thermal conductivity is not affected by the thickness of the product. Conductivity is inversely proportional to the thermal efficiency of the material.

#### b. R-Value (Thermal Resistance)s

Thermal resistance is the ability of a material to prevent the passage of heat. It's the thickness of the material (in metres) divided by its conductivity. This is expressed as m<sup>2</sup>K/W.

If the material consists of several elements, the overall resistance is the total of the resistances of each element. The efficiency of the material is directly proportional to the R-value.

#### c. U-Value (Thermal Transmittance)

Thermal transmittance, commonly known as the U-value, is a measure of the rate of heat loss of a building component. The U-value is the sum of the combined thermal resistances of

all the elements in a construction, including surfaces, air spaces, and the effects of any thermal bridges, air gaps and fixings.

### Steps for Calculation –

- 1.) **Equation 1** for calculating U-value

$$U = \frac{1}{(R_1 + R_2 + R_3 + R_4 + \dots + R_n)}$$















- 2.) **Equation 2** for calculation R

$$R = \frac{\text{Thickness in of material (m)}}{\text{Thermal conductivity or } \lambda \text{ value (k)}}$$

- 3.) Using equation 1 & 2 U value can be calculated

## Wall Assemblies

### LEGEND

	Plaster
	Brick wall
	EPS
	Polyurethane
	XPS insulation
	Bonded mineral wool
	Hollow concrete blockwork
	AAC Block wall
	Air gap
	Insulated block work
	Glass fibre & Mineral fibre
	Cement stabilized brick wall
	Internal bonded mineral wool
	Fly ash brick wall
	Gypsum Board
	Single Glass unit (6mm)

**W1** -Brick Wall Mass Wall with internal insulation and plaster on both sides Expanded polystyrene (EPS) 100mm.

S.No	Material type	Thickness (m)	Conductivity (W/m-K)	R value m <sup>2</sup> K/W
1	Outer Plaster	0.01	0.73	0.02
2	Brick wall	0.23	0.72	0.32
3	EPS	0.1	0.38	2.63
4	Inner Plaster	0.01	0.73	0.01
<b>U value of assembly</b>				<b>0.33</b>

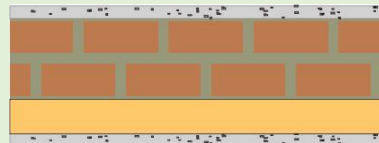

**W2**-Brick Wall with external insulation and plaster on both sides with Extruded polystyrene (XPS)

S.No	Material type	Thickness (m)	Conductivity (W/m-K)	R value m <sup>2</sup> K/W
1	Outer Plaster	0.01	0.73	0.02
2	XPS	0.03	0.02	0.90
3	Inner Brick Wall	0.23	0.72	0.32

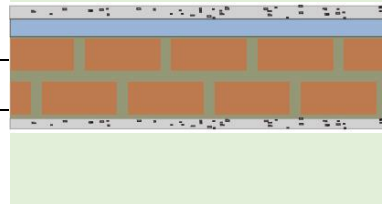

4	Inner Plaster	0.01	0.73	0.01
<b>U value of assembly</b>				<b>0.80</b>

**W3-Brick Wall with internal insulation and plaster on both sides with Polyurethane**

S.No	Material type	Thickness (m)	Conductivity (W/m-K)	R value m <sup>2</sup> K/W
1	Outer Plaster	0.01	0.73	0.02
2	Polyurethane	0.05	0.02	2.15
3	Inner Brick Wall	0.23	0.72	0.32
4	Inner Plaster	0.01	0.73	0.01
<b>U value of assembly</b>				<b>0.40</b>

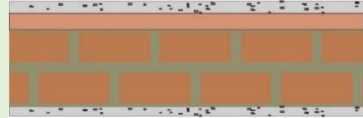

**W4-Brick Wall - Cavity Wall (external heavy mass) & both sides plaster with Bonded Mineral wool**

S.No	Material type	Thickness (m)	Conductivity (W/m-K)	R value m <sup>2</sup> K/W
1	Outer Plaster	0.012	0.73	0.03
2	Outer Brick wall	0.23	0.72	0.33
3	Bonded Mineral wool	0.025	0.03	0.74
4	Inner Brick Wall	0.115	0.72	0.16
5	Inner Plaster	0.008	0.73	0.01
<b>U value of assembly</b>				<b>0.80</b>

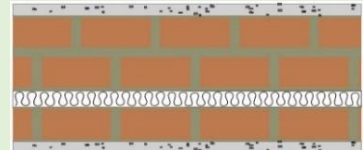

**W5-** Brick Wall - Cavity Wall (both side heavy) & both sides plaster with Glass fiber & mineral fiber

S.No	Material type	Thickness (m)	Conductivity (W/m-K)	R value m <sup>2</sup> K/W
1	Outer Plaster	0.012	0.729225	0.0164
2	Outer Brick wall	0.23	0.720125	0.319
3	Glass fiber & Mineral fiber	0.1	0.0329	3.04
4	Inner Brick Wall	0.23	0.720125	0.319
5	Inner Plaster	0.008	0.729225	0.0109
<b>U value of assembly</b>				<b>0.27</b>

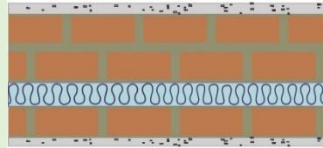

**W6-** Cement Stabilized Brick Wall with internal insulation and plaster on both sides with Bonded Mineral wool

S.No	Material type	Thickness (m)	Conductivity (W/m-K)	R value m <sup>2</sup> K/W
1	Outer Plaster	0.01	0.73	0.02
2	Cement Stabilized Brick Wall	0.25	0.65	0.38
3	Internal Bonded Mineral wool	0.05	0.03	1.47
4	Inner Plaster	0.01	0.73	0.01
<b>U value of assembly</b>				<b>0.50</b>

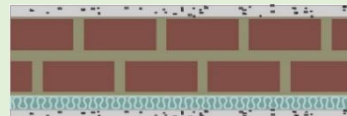

**W7**-Fly ash brick wall with internal insulation and plaster on both sides – Extruded polystyrene (XPS)

S.No	Material type	Thickness (m)	Conductivity (W/m-K)	R value m <sup>2</sup> K/W
1	Outer Plaster	0.12	0.73	0.02
2	Fly-Ash brick wall	0.2	0.54	0.37
3	XPS insulation	0.1	0.03	3.57
4	Inner Plaster	0.008	0.73	0.01
<b>U value of assembly</b>				<b>0.24</b>

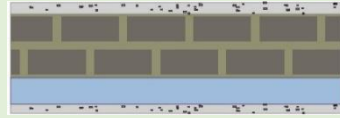

**W8**- Fly ash brick cavity wall (internal heavy mass) & both side plaster and Polyurethane

S.No	Material type	Thickness (m)	Conductivity (W/m-K)	R value m <sup>2</sup> K/W
1	Outer Plaster	0.01	0.73	0.02
2	Outer Fly-Ash brick wall	0.1	0.54	0.19
3	Polyurethane	0.1	0.02	4.3
4	Inner Fly-Ash brick wall	0.2	0.54	0.37
5	Inner Plaster	0.01	0.73	0.01
<b>U value of assembly</b>				<b>0.20</b>

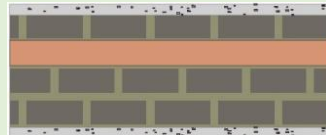

**W9**-Hollow concrete block wall with external insulation and plaster on both sides with XPS

S.No	Material type	Thickness (m)	Conductivity (W/m-K)	R value m <sup>2</sup> K/W
1	Outer Plaster	0.01	0.73	0.02
2	XPS	0.1	0.03	3.57
3	Hollow concrete block wall	0.2	0.36	0.55
4	Inner Plaster	0.01	0.73	0.01

**U value of assembly**

**0.23**

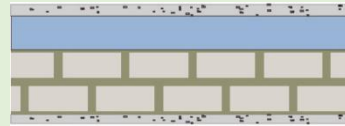

**W10**- Autoclaved aerated concrete (AAC) block wall with plaster on both sides

S.No	Material type	Thickness (m)	Conductivity (W/m-K)	R value m <sup>2</sup> K/W
1	Outer Plaster	0.01	0.73	0.02
2	AAC block wall	0.2	0.14	1.43
3	Inner Plaster	0.01	0.73	0.01

**U value of assembly**

**0.70**



**W11**-Autoclaved aerated concrete block cavity wall (internal heavy mass) with plaster on both sides

S.No	Material type	Thickness (m)	Conductivity (W/m-K)	R value m <sup>2</sup> K/W
1	Outer Plaster	0.012	0.73	0.02
2	Outer AAC block wall	0.2	0.14	1.43
3	Air Gap	0.1	-	0.16

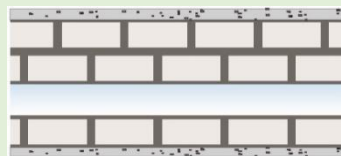

4	Inner AAC block wall	0.1	0.14	0.71
5	Inner Plaster	0.01	0.73	0.01
<b>U value of assembly</b>				<b>0.43</b>

**W12-Insulated Block Wall with plaster on both sides**

S.No	Material type	Thickness (m)	Conductivity (W/m-K)	R value m <sup>2</sup> K/W
1	Outer Plaster	0.01	0.73	0.02
2	Insulated Block Wall	0.3	0.08	3.73
3	Inner Plaster	0.01	0.73	0.01
<b>U value of assembly</b>				<b>0.27</b>

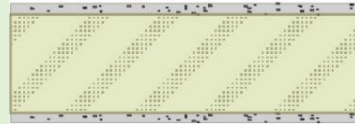

**W13-Gypsum cavity wall with Expanded polystyrene (EPS) insulation**

S.No	Material type	Thickness (m)	Conductivity (W/m-K)	R value m <sup>2</sup> K/W
1	Outer Gypsum wall	0.01	0.16	0.08
2	EPS	0.1	0.04	2.63
3	Inner Gypsum Wall	0.01	0.16	0.08
<b>U value of assembly</b>				<b>0.36</b>





**W14-Gypsum cavity wall with inner insulation Polyurethane**

S.No	Material type	Thickness (m)	Conductivity (W/m-K)	R value m <sup>2</sup> K/W
1	Outer Gypsum wall	0.01	0.16	0.08
2	Polyurethane	0.1	0.02	4.3
3	Inner Gypsum Wall	0.01	0.16	0.08
<b>U value of assembly</b>				<b>0.22</b>

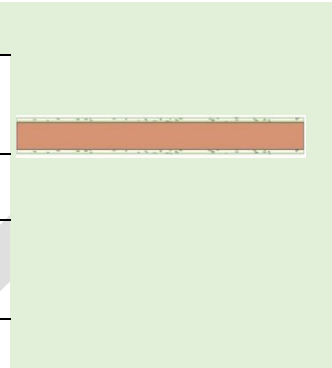

**W15-Curtain cavity wall with Bonded Mineral wool insulation**



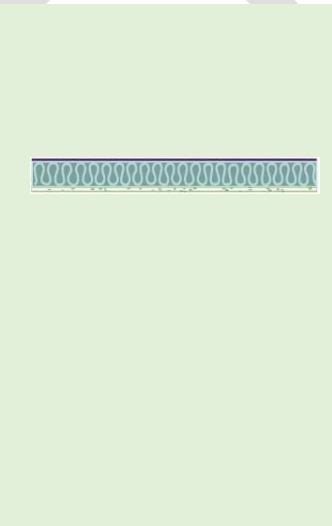





S.No	Material type	Thickness (m)	Conductivity (W/m-K)	R value m <sup>2</sup> K/W
1	Single glass unit (6 mm)	0.01	-	0.35
2	Bonded Mineral wool (Rock/glass wool) 100 mm	0.1	0.03	3.04
3	Gypsum board	0.01	0.16	0.08
<b>U-value of assembly</b>				<b>0.30</b>



## Appendix C

### Roof Assemblies

#### LEGEND

	Plaster
	Brick wall
	EPS
	Polyurethane
	XPS insulation
	Bonded mineral wool
	Glass fibre & Mineral fibre
	RCC Slab

#### R1 -Overdeck Polyurethane Insulation

S.No	Material type	Thickness (m)	Conductivity (W/m-K)	R value m <sup>2</sup> K/W
1	Inner Plaster	0.01	0.73	0.02
2	RCC Slab	0.15	1.67	0.09
3	Polyurethane	0.1	0.02	4.30
4	External Plaster	0.01	0.67	0.02



**U value of assembly**

**0.23**

#### R2-Overdeck Extruded polystyrene (XPS) Insulation

S.No	Material type	Thickness (m)	Conductivity (W/m-K)	R value m <sup>2</sup> K/W
1	Inner Plaster	0.01	0.73	0.02
2	RCC Slab	0.15	1.67	0.09
3	XPS	0.1	0.03	3.54
4	Cement Mortar	0.03	0.67	0.04
5	Brick Bat Coba	0.08	0.63	0.12

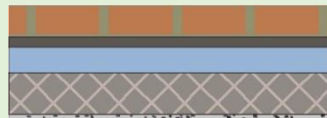

**U value of assembly**

**0.26**

### R3- Overdeck Expanded polystyrene (thermocole) (EPS) Insulation

S.No	Material type	Thickness (m)	Conductivity (W/m-K)	R value m <sup>2</sup> K/W
1	Inner Plaster	0.01	0.73	0.02
2	RCC Slab	0.15	1.67	0.09
3	Cement Mortar	0.03	0.67	0.04
4	EPS	0.1	0.04	2.63
5	Brick Bat Coba	0.08	0.63	0.12
<b>U value of assembly</b>				<b>0.35</b>

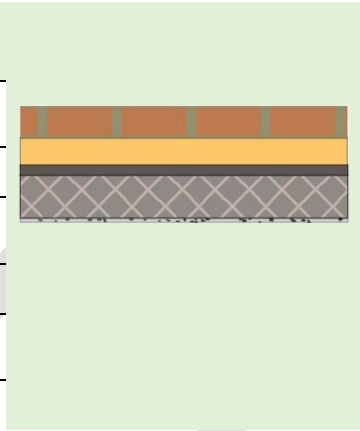

### R4 - Underdeck Polyurethane Insulation

S.No	Material type	Thickness (m)	Conductivity (W/m-K)	R value m <sup>2</sup> K/W
1	Inner Plaster	0.01	0.73	0.02
2	Polyurethane	0.1	0.02	4.30
2	RCC Slab	0.15	1.67	0.09
4	Cement Mortar	0.03	0.67	0.04
5	Brick Bat Coba	0.1	0.63	0.16
<b>U value of assembly</b>				<b>0.22</b>

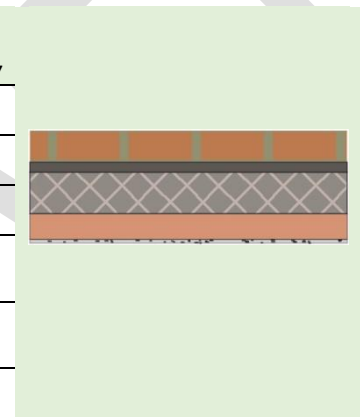

### R5- Underdeck Glass Fiber and Mineral Fiber Insulation

S.No	Material type	Thickness (m)	Conductivity (W/m-K)	R value m <sup>2</sup> K/W
1	Inner Plaster	0.01	0.73	0.02
2	Glass fiber and mineral fiber	0.1	0.03	3.04

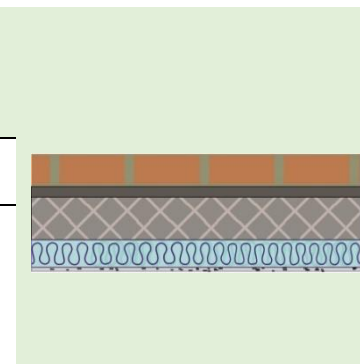

2	RCC Slab	0.15	1.67	0.09
4	Cement Mortar	0.03	0.67	0.04
5	Brick Bat Coba	0.1	0.63	0.16
<b>U value of assembly</b>				<b>0.30</b>

**R6- Underdeck Bonded Mineral Wool Insulation**

S.No	Material type	Thickness (m)	Conductivity (W/m-K)	R value m <sup>2</sup> K/W
1	Inner Plaster	0.01	0.73	0.02
2	Bonded Mineral Wool	0.1	0.03	2.94
2	RCC Slab	0.15	1.67	0.09
4	Cement Mortar	0.03	0.67	0.04
5	Brick Bat Coba	0.1	0.63	0.16
<b>U value of assembly</b>				<b>0.31</b>

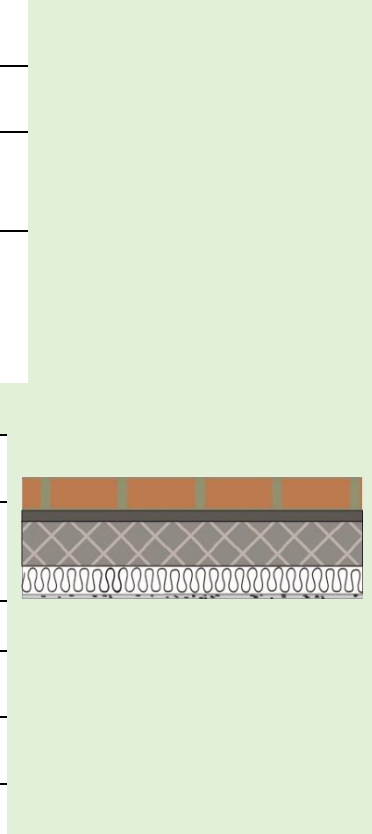

## Appendix D

### D.1 Mechanical and Motor Efficiency requirements for Fans in ECBC, ECBC+ and SuperECBC Buildings

Table D- 1 Mechanical and Motor Efficiency Requirements for Fans in ECBC Buildings

System type	Fan Type	Mechanical Efficiency	Motor Efficiency (As per IS 12615)
Air-handling unit	Supply, return and exhaust	60%	IE 2

Table D- 2 Mechanical and Motor Efficiency Requirements for Fans in ECBC+ Buildings

System type	Fan Type	Mechanical Efficiency	Motor Efficiency (As per IS 12615)
Air-handling unit	Supply, return and exhaust	65%	IE 3

Table D- 3 Mechanical and Motor Efficiency Requirements for Fans in SuperECBC Buildings

System Type	Fan Type	Mechanical Efficiency	Motor Efficiency (As per IS 12615)
Air-handling unit	Supply, return and exhaust	70%	IE 4

### D.2 Pump Efficiency requirements for ECBC, ECBC+ and SuperECBC Buildings

Table D- 4 Pump Efficiency Requirements for ECBC Building

Equipment	ECBC
Chilled Water Pump (Primary and Secondary)	18.2 W/ kW <sub>r</sub> with VFD on secondary pump
Condenser Water Pump	17.7 W/ kW <sub>r</sub>
Pump Efficiency (minimum)	70%

Table D- 5 Pump Efficiency Requirements for ECBC+ Building

<i>Equipment</i>	<i>ECBC+ Building</i>
Chilled Water Pump (Primary and Secondary)	16.9 W/ kW <sub>r</sub> with VFD on secondary pump
Condenser Water Pump	16.5 W/ kW <sub>r</sub>
Pump Efficiency (minimum)	75%

Table D- 6 Pump Efficiency Requirements for SuperECBC Building

<i>Equipment</i>	<i>SuperECBC Building</i>
Chilled Water Pump (Primary and Secondary)	14.9 W/ kW <sub>r</sub> with VFD on secondary pump
Condenser Water Pump	14.6 W/ kW <sub>r</sub>
Pump Efficiency (minimum)	85%

### D.3 Cooling Tower efficiency requirements for ECBC, ECBC+ and SuperECBC Buildings

Table D- 7 Cooling Tower Efficiency Requirements for ECBC, ECBC+, and SuperECBC Buildings

<i>Equipment type</i>	<i>Rating Condition</i>	<i>Efficiency</i>
Open circuit cooling tower Fans	35°C entering water	0.017 kW/kW <sub>r</sub>
	29°C leaving water	0.31 kW/ L/s
	24°C WB outdoor air	

### D.4 Boiler efficiency requirements for ECBC, ECBC+ and SuperECBC Buildings

Gas and oil fired boilers shall meet or exceed the minimum efficiency requirements specified:

Table D- 8 Minimum Efficiency Requirements for Oil and Gas Fired Boilers for ECBC building

<i>Equipment Type</i>	<i>Sub Category</i>	<i>Size Category</i>	<i>Minimum FUE</i>
Boilers, Hot Water	Gas or oil fired	All capacity	80%
FUE - fuel utilization efficiency			

Table D- 9 Minimum Efficiency Requirements for Oil and Gas Fired Boilers for ECBC+ and SuperECBC building

<i>Equipment Type</i>	<i>Sub Category</i>	<i>Size Category</i>	<i>Minimum FUE</i>
Boilers, Hot Water	Gas or oil fired	All capacity	85%
FUE - fuel utilization efficiency			

DRAFT

## Appendix E

### Piping Insulation

Piping for heating, space conditioning, and service hot water systems shall meet the insulation requirements listed in **Error! Reference source not found.** through **Error! Reference source not found.**. Insulation exposed to weather shall be protected by aluminium sheet metal, painted canvas, or plastic cover. Cellular foam insulation shall be protected as above, or be painted with water retardant paint.

Exceptions to § 0:

- (a) Reduction in insulation R value by 0.2 (compared to values in **Error! Reference source not found.**, Table E- 2 and Table E- 3) to a minimum insulation level of R-0.4 shall be permitted for any pipe located in partition within a conditioned space or buried.
- (b) Insulation R value shall be increased by 0.2 over and above the requirement stated in Table E- 1 through **Error! Reference source not found.** for any pipe located in a partition outside a building with direct exposure to weather.
- (c) Reduction in insulation R value by 0.2 (compared to values in **Error! Reference source not found.**, Table E- 2 and **Error! Reference source not found.**) to a minimum insulation level of R-0.4 shall be permitted for buildings in Temperate climate zone.



Table E- 1 Insulation Requirements for Pipes in ECBC Building

Operating Temperature (°C)	Pipe size (mm)	
	<25	>=40
	Insulation R value (m <sup>2</sup> .K/W)	
<b>Heating System</b>		
94°C to 121°C	0.9	1.2
60°C to 94°C	0.7	0.7
40°C to 60°C	0.4	0.7
<b>Cooling System</b>		
4.5°C to 15°C	0.4	0.7
< 4.5°C	0.9	1.2
<b>Refrigerant Piping (Split systems)</b>		
4.5°C to 15°C	0.4	0.7
< 4.5°C	0.9	1.2

Table E- 2 Insulation Requirements for Pipes in ECBC+ Building

Operating Temperature (°C)	Pipe size (mm)	
	< 40	>=40
	Insulation R value (m <sup>2</sup> .K/W)	
<b>Heating System</b>		
94°C to 121°C	1.1	1.3
60°C to 94°C	0.8	0.8
40°C to 60°C	0.5	0.9
<b>Cooling System</b>		
4.5°C to 15°C	0.5	0.9
< 4.5°C	1.1	1.3
<b>Refrigerant Piping (Split Systems)</b>		
4.5°C to 15°C	0.5	0.9
< 4.5°C	1.1	1.3

Table E- 3 Insulation Requirements for Pipes in SuperECBC Buildings

Operating Temperature (°C)	Pipe size (mm)	
	< 40	>=40
	Insulation R value (m <sup>2</sup> .K/W)	
<b>Heating System</b>		
94°C to 121°C	1.5	1.5
60°C to 94°C	1.0	1.3
40°C to 60°C	0.7	1.1
<b>Cooling System</b>		
4.5°C to 15°C	0.7	1.2
< 4.5°C	1.5	1.5
<b>Refrigerant Piping (Split Systems)</b>		
4.5°C to 15°C	0.4	0.7
< 4.5°C	1.5	1.5

### Ductwork and Plenum Insulation

Ductwork and plenum shall be insulated in accordance with Table E- 4

Table E- 4 Ductwork Insulation (R value in m<sup>2</sup> . K/W) Requirements

Duct Location	Supply ducts	Return ducts
Exterior	R -1.4	R -0.6
Unconditioned Space	R -0.6	None
Buried	R -0.6	None

## Appendix F

Table F- 1 Interior Lighting Power for ECBC Buildings – Building Area Method

<i>Building Type</i>	<i>LPD (W/m<sup>2</sup>)</i>	<i>Building Area Type</i>	<i>LPD (W/m<sup>2</sup>)</i>
Office Building	9.50	Motion picture theatre	9.43
Hospitals	9.70	Museum	10.2
Hotels	9.50	Post office	10.5
Shopping Mall	14.1	Religious building	12.0
University and Schools	11.2	Sports arena	9.70
Library	12.2	Transportation	9.20
Dining: bar lounge/leisure	12.2	Warehouse	7.08
Dining: cafeteria/fast food	11.5	Performing arts theatre	16.3
Dining: family	10.9	Police station	9.90
Dormitory	9.10	Workshop	14.1
Fire station	9.70	Automotive facility	9.00
Gymnasium	10.0	Convention centre	12.5
Manufacturing facility	12.0	Parking garage	3.00

In cases where both a general building area type and a specific building area type are listed, the specific building area type shall apply.

Table F- 2 Interior Lighting Power for ECBC+ Buildings – Building Area Method

Building Area Type	LPD (W/m <sup>2</sup> )	Building Area Type	LPD (W/m <sup>2</sup> )
Office Building	7.60	Motion picture theater	7.50
Hospitals	7.80	Museum	8.20
Hotels	7.60	Post office	8.40
Shopping Mall	11.3	Religious building	9.60
University and Schools	9.00	Sports arena	7.80
Library	9.80	Transportation	7.40
Dining: bar lounge/leisure	9.80	Warehouse	5.70
Dining: cafeteria/fast food	9.20	Performing arts theater	13.0
Dining: family	8.70	Police station	7.90
Dormitory	7.30	Workshop	11.3
Fire station	7.80	Automotive facility	7.20
Gymnasium	8.00	Convention center	10.0
Manufacturing facility	9.60	Parking garage	2.40
In cases where both a general building area type and a specific building area type are listed, the specific building area type shall apply.			

Table F- 3 Interior Lighting Power for SuperECBC Buildings – Building Area Method

Building Area Type	LPD (W/m <sup>2</sup> )	Building Area Type	LPD (W/m <sup>2</sup> )
Office Building	5.0	Motion picture theatre	4.7
Hospitals	4.9	Museum	5.1
Hotels	4.8	Post office	5.3
Shopping Mall	7.0	Religious building	6.0
University and Schools	6.0	Sports arena	4.9
Library	6.1	Transportation	4.6
Dining: bar lounge/leisure	6.1	Warehouse	3.5

Dining: cafeteria/fast food	5.8	Performing arts theatre	8.2
Dining: family	5.5	Police station	5.0
Dormitory	4.6	Workshop	7.1
Fire station	4.9	Automotive facility	4.5
Gymnasium	5.0	Convention centre	6.3
Manufacturing facility	6.0	Parking garage	1.5
In cases where both a general building area type and a specific building area type are listed, the specific building area type shall apply.			

DRAFT

Table F- 4 Interior Lighting Power for ECBC Buildings – Space Function Method

<i>Category</i>	<i>LPD (W/m<sup>2</sup>)</i>	<i>Lamp category</i>	<i>LPD (W/m<sup>2</sup>)</i>
<b>Common Space Types</b>			
Restroom	7.70	Stairway	5.50
Storage	6.80	Corridor/Transition	7.10
Conference/ Meeting	11.5	Lobby	9.10
Parking Bays (covered/ basement)	2.20	Parking Driveways (covered/ basement)	3.00
Electrical/Mechanical	7.10	Workshop	17.1
<b>Business</b>			
Enclosed	10.0	Open Plan	10.0
Banking Activity Area	12.6	Service/Repair	6.80
<b>Healthcare</b>			
Emergency	22.8	Recovery	8.60
Exam/Treatment	13.7	Storage	5.50
Nurses' Station	9.40	Laundry/Washing	7.50
Operating Room	21.8	Lounge/Recreation	8.00
Patient Room	7.70	Medical Supply	13.7
Pharmacy	10.7	Nursery	5.70
Physical Therapy	9.70	Corridor/Transition	9.10
Radiology/Imaging	9.10		
<i>Category</i>	<i>LPD (W/m<sup>2</sup>)</i>	<i>Lamp category</i>	<i>LPD (W/m<sup>2</sup>)</i>
<b>Hospitality</b>			
Hotel Dining	9.10	Hotel Lobby	10.9
For Bar Lounge/ Dining	14.1	Motel Dining	9.10
For food preparation	12.1	Motel Guest Rooms	7.70
Hotel Guest Rooms	9.10		
<b>Shopping Complex</b>			
Mall Concourse	12.8	For Family Dining	10.9

Sales Area	18.3	For food preparation	12.1
Motion Picture Theatre	9.60	Bar Lounge/ Dining	14.1
<b>Educational</b>			
Classroom/Lecture	13.7	Card File and Cataloguing	9.10
For Classrooms	13.8	Stacks (Lib)	18.3
Laboratory	15.1	Reading Area (Library)	10.0
<b>Assembly</b>			
Dressing Room	9.10	Seating Area - Performing Arts Theatre	22.6
Exhibit Space - Convention Centre	14.0	Lobby - Performing Arts Theatre	21.5
Seating Area - Gymnasium	4.60	Seating Area - Convention Centre	6.40
Fitness Area - Gymnasium	13.70	Seating Religious Building	16.4
Museum - General Exhibition	16.40	Playing Area - Gymnasium	18.8
Museum - Restoration	18.3		

Table F- 5 Interior Lighting Power for ECBC+ Buildings – Space Function Method

<i>Category</i>	<i>LPD (W/m<sup>2</sup>)</i>	<i>Lamp category</i>	<i>LPD (W/m<sup>2</sup>)</i>
<b>Common Space Types</b>			
Restroom	6.10	Stairway	4.40
Storage	5.40	Corridor/Transition	3.60
Conference/ Meeting	9.20	Lobby	7.30
Parking Bay (covered/ basement)	1.75	Parking Driveways (covered/ basement)	2.50
Electrical/Mechanical	5.70	Workshop	13.7
<b>Business</b>			
Enclosed	8.60	Open Plan	8.60
Banking Activity Area	9.30	Service/Repair	5.50
<b>Healthcare</b>			
Emergency	18.2	Recovery	7.00
Exam/Treatment	10.9	Storage	4.40
Nurses' Station	7.50	Laundry/Washing	6.00
Operating Room	17.5	Lounge/Recreation	6.40
Patient Room	6.10	Medical Supply	10.9
Pharmacy	8.50	Nursery	4.60
Physical Therapy	7.80	Corridor/Transition	7.30
Radiology/Imaging	7.30		
<b>Hospitality</b>			
Hotel Dining	7.30	Hotel Lobby	8.80
For Bar Lounge/ Dining	11.3	Motel Dining	7.30
For food preparation	12.1	Motel Guest Rooms	6.10
Hotel Guest Rooms	7.30		
<b>Shopping Complex</b>			
Mall Concourse	10.2	For Family Dining	8.80
Sales Area	14.6	For food preparation	12.1



Motion Picture Theatre	10.3	Bar Lounge/ Dining	11.3
<b>Educational</b>			
Classroom/Lecture	10.9	Card File and Cataloguing	7.30
For Classrooms	11.0	Stacks (Library)	14.6
Laboratory	12.1	Reading Area (Library)	9.20
<b>Assembly</b>			
Dressing Room	7.30	Seating Area - Performing Arts Theatre	18.1
<i>Category</i>	<i>LPD (W/m<sup>2</sup>)</i>	<i>Lamp category</i>	<i>LPD (W/m<sup>2</sup>)</i>
Exhibit Space - Convention Centre	11.2	Lobby - Performing Arts Theatre	17.2
Seating Area - Gymnasium	3.60	Seating Area – Convention Centre	5.10
Fitness Area - Gymnasium	7.85	Seating Religious Building	13.1
Museum - General Exhibition	11.3	Playing Area - Gymnasium	12.9
Museum - Restoration	11.0		

Table F- 6 Interior Lighting Power for SuperECBC Buildings – Space Function Method

<i>Category</i>	<i>LPD (W/m<sup>2</sup>)</i>	<i>Lamp category</i>	<i>LPD (W/m<sup>2</sup>)</i>
<b>Common Space Types</b>			
Restrooms	3.80	Stairway	2.70
Storage	3.40	Corridor/Transition	2.30
Conference/ Meeting	5.70	Lobby	4.60
Parking Bays (covered/ basement)	1.10	Driveways (covered/ basement)	1.50
Electrical/Mechanical	3.50	Workshop	8.60
<b>Business</b>			
Enclosed	5.40	Open Plan	5.40
Banking Activity Area	5.80	Service/Repair	3.40
<b>Healthcare</b>			

Emergency	11.4	Recovery	4.40
Exam/Treatment	6.80	Storage	2.70
Nurses' Station	5.00	Laundry/Washing	3.80
Operating Room	10.9	Lounge/Recreation	4.60
Patient Room	3.80	Medical Supply	6.80
Pharmacy	5.30	Nursery	2.90
Physical Therapy	4.90	Corridor/Transition	4.60
Radiology/Imaging	4.60		
<b>Hospitality</b>			
Hotel Dining	4.60	Hotel Lobby	5.50
For Bar Lounge/ Dining	7.00	Motel Dining	4.60
For food preparation	7.50	Motel Guest Rooms	3.80
Hotel Guest Rooms	4.60		
<b>Shopping Complex</b>			
Mall Concourse	6.40	For Family Dining	5.50
<i>Category</i>	<i>LPD (W/m<sup>2</sup>)</i>	<i>Lamp category</i>	<i>LPD (W/m<sup>2</sup>)</i>
Sales Area	9.20	For food preparation	7.50
Motion Picture Theatre	6.50	Bar Lounge/ Dining	7.00
<b>Educational</b>			
Classroom/Lecture	6.80	Card File and Cataloguing	4.60
For Classrooms	6.90	Stacks (Library)	9.20
Laboratory	7.50	Reading Area (Library)	5.70
<b>Assembly</b>			
Dressing Room	4.60	Seating Area - Performing Arts Theatre	11.3
Exhibit Space – Convention Centre	7.00	Lobby - Performing Arts Theatre	10.8
Seating Area - Gymnasium	3.40	Seating Area – Convention Centre	3.20
Fitness Area - Gymnasium	3.92	Seating Religious Building	8.20
Museum – General Exhibition	5.65	Playing Area - Gymnasium	6.50

Museum – Restoration	5.50
----------------------	------

Table F- 7 Exterior Building Lighting Power for ECBC Buildings

Exterior lighting application	Power limits
Building entrance (with canopy)	10 W/m <sup>2</sup> of canopied area
Building entrance (w/o canopy)	90 W/ linear m of door width
Building exit	60 W/lin m of door width
Building façade	5.0 W/m <sup>2</sup> of vertical façade area
Emergency signs, ATM kiosks, Security areas façade	1.0 W/m <sup>2</sup>
Driveways and parking (open/ external)	1.6 W/m <sup>2</sup>
Pedestrian walkways	2.0 W/m <sup>2</sup>
Stairways	10.0 W/m <sup>2</sup>
Landscaping	0.5 W/m <sup>2</sup>
Outdoor sales area	9.0 W/m <sup>2</sup>

Table F- 8 Exterior Building Lighting Power for ECBC+ Buildings

Exterior lighting application	Power limits
Building entrance (with canopy)	8.0 W/m <sup>2</sup> of canopied area
Building entrance (w/o canopy)	72 W/ linear m of door width
Building exit	48 W/lin m of door width
Building façade	4.0 W/m <sup>2</sup> of vertical façade area
Emergency signs, ATM kiosks, Security areas façade	0.8 W/m <sup>2</sup>
Driveways and parking (open/ external)	1.3 W/m <sup>2</sup>
Pedestrian walkways	1.6 W/m <sup>2</sup>
Stairways	8.0 W/m <sup>2</sup>
Landscaping	0.4 W/m <sup>2</sup>
Outdoor sales area	7.2 W/m <sup>2</sup>

Table F- 9 Exterior Building Lighting Power for SuperECBC Buildings

<i>Exterior lighting application</i>	<i>Power limits</i>
Building entrance (with canopy)	5.0 W/m <sup>2</sup> of canopied area
Building entrance (w/o canopy)	45 W/ linear m of door width
Building exit	30 W/lin m of door width
Building façade	2.5 W/m <sup>2</sup> of vertical façade area
Emergency signs, ATM kiosks, Security areas façade	0.5 W/m <sup>2</sup>
Driveways and parking (open/ external)	0.8 W/m <sup>2</sup>
Pedestrian walkways	1.0 W/m <sup>2</sup>
Stairways	5.0 W/m <sup>2</sup>
Landscaping	0.25 W/m <sup>2</sup>
Outdoor sales area	4.5 W/m <sup>2</sup>



**Bureau of Energy Efficiency**

4th Floor, Sewa Bhawan, R. K.Puram, New Delhi - 110066

[www.beeindia.gov.in](http://www.beeindia.gov.in)